

THE BORDEAUX's

A COLLABORATION BETWEEN CURT CAMPBELL
AND JIM HOLTZ



DESIGN BY: JIM HOLTZ
CROSSOVER BY: CURT CAMPBELL
OCTOBER 17, 2017

Bordeaux BOM

Drivers:

- (4) RS225-8 Dayton woofers
- (2) Accuton C158-8-085 woofers
- (2) Aurum Cantus AST2560 AMT

Drivers Sub Total

Crossover Components:

Caps:

- (4) 100.0 uF Clarity PX caps
- (2) 18.0 uF Clarity PX caps
- (4) 6.8 uF Clarity PX caps

Resistors:

- (2) 8.2 ohm Lynx resistors
- (2) 2.0 ohm Lynx resistors
- (2) 1.0 ohm Lynx resistors

Inductors:

- (2) 5.0 mH 16 gauge Steel Laminate
- (2) .210 mH 18 gauge Air Core
- (2) 1.5 mH 18 gauge Air Core
- (2) .50 mh 18gauge Air core

Miscellaneous Items

- (2) 3" Precision Ports
with tube length cut to 5" plus
inner and outer flares (PSP3-
BKHT)
- (4) Neutrik NL4FC
- (4) Neutrik NL4MP SpeakOn Connector 4 Pole
Panel mount

8 ordeaux Crossover

Net

L1011 5.G:>DmH
 C1021 1.1:1ufl uF

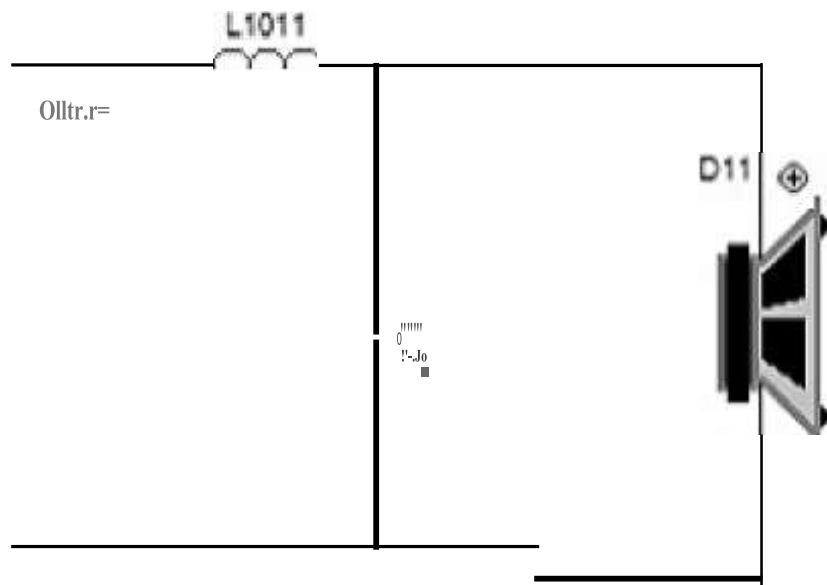

Net2

Un 100.00 uF
 1 d.500 ohm
 R2033 4.00 ohm
 C2031 3.300 uF
 L: "ffl 0.500 mH
 C2041 20.00 uF
 R2051 100 01m

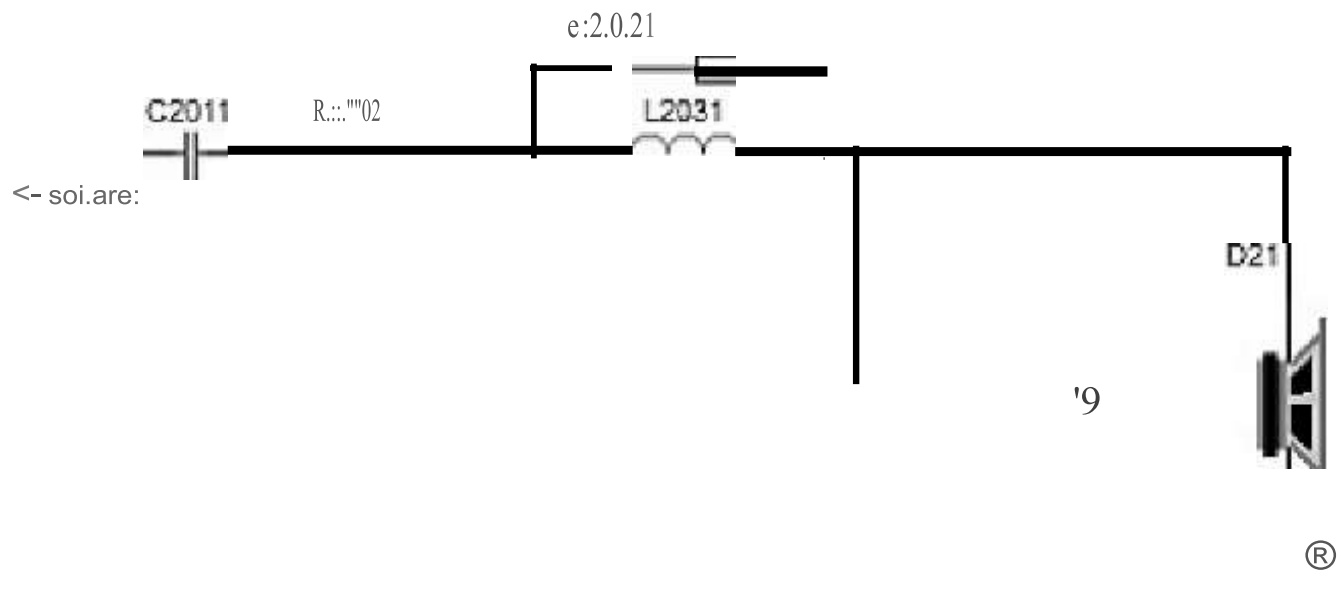

Net.3

C3011 8.200 uF
 R3021 2.70 ohm
 C3021
 0. .iIDl) mH
 R3041 .Me'

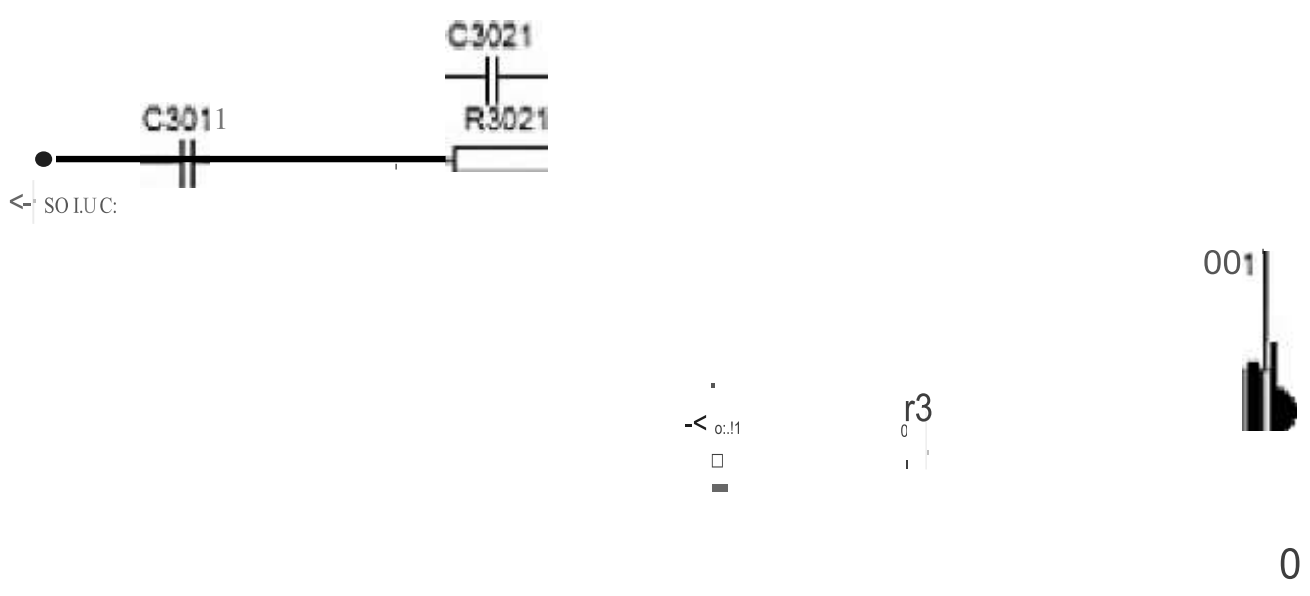

49"

27 1/2"

21 1/4"

0,0,0,0

Inner Front & Rear Baffle

0,0,0,0

Top & Bottom panel

27 1/2"

0,0,0,0

Inner Front & Rear Baffle

10"

qTop Vertical Brace

10"

oTop Vertical Brace

27 1/2"

0,0,0,0

Inner Front & Rear Baffle

19 3/4"

0,0,0,0

Shelf Brace

29"

0,0,0,0

Front Baffle

19 3/4"

0,0,0,0

Shelf Brace

19 3/4"

0,0,0,0

Shelf Brace

19 3/4"

0,0,0,0

Shelf Brace

1:0
0
3

0
0
3

0,0,0,0

11 1/2"

0,0,0,0

0
0
3

29"

0,0,0,0

Sides

1:0
0
3

0
0
3

7:58"

0
0
3

29"

0,0,0,0

Sides

7:58"

0
0
3

10"

0
0
3

7:58"

0
0
3

97 "

•
.....
N
Top Cabinet Top & Bottom

•
.....
N
Top Cabinet Top & Bottom

•
.....
N
Top Cabinet Top & Bottom

•
.....
N
p ea.binet Inner Front & Rear Ba

•
.....
N
p ea.binet Inner Front & Rear Ba

•
.....
N
p ea.binet Inner Front & Rear Ba

•
.....
N
p ea.binet Inner Front & Rear Ba e

•
.....
N
Sides
29"

•
.....
N
Sides
29"

•
.....
N
a.
10"

•
.....
N
a.
10"

•
.....
N
13 1/2"

•
.....
N
Top Cabinet Sides
14 1/2"

•
.....
N
Top Cabinet Sides
14 1/2"

•
.....
N
Top Cabinet Sides
14 1/2"

•
.....
N
a.

•
.....
N
Inner Front & Rear Baffle

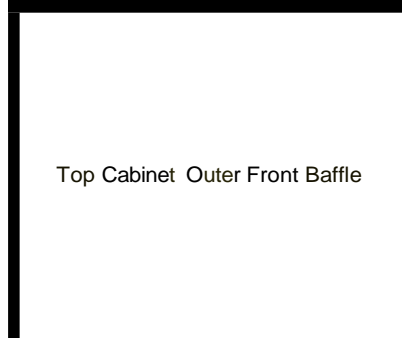
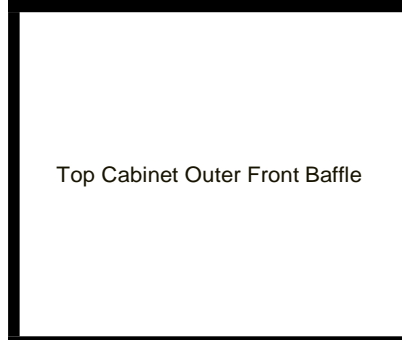
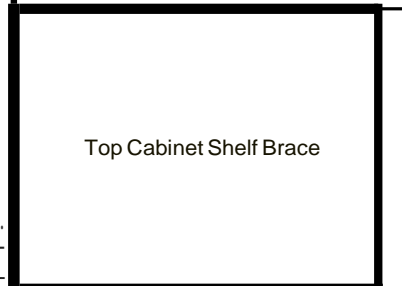
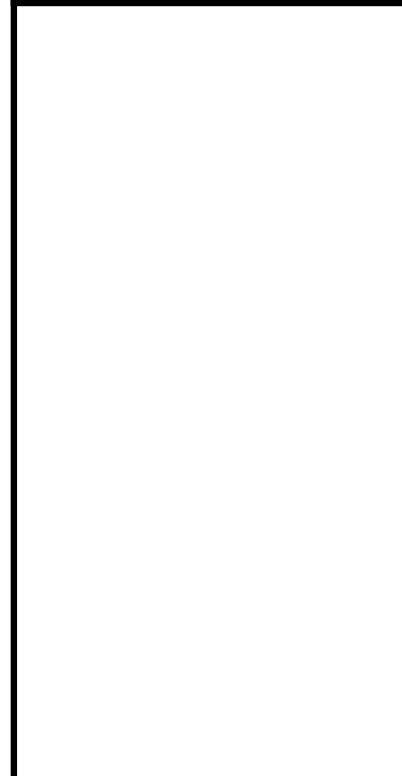

10
...
...
r

Top Cabinet Shelf Brace

Top Cabinet Shelf Brace

Top Cabinet Outer Front Baffle

Top Cabinet Outer Front Baffle

Input Item List

Client Name :	Job Reference :
Phone Number :	Quote Number :
Fax Number :	Quantity : 11
Address :	Date Required : 8/9/2017

Input Panel

Code	Material	Length	Width	Qty	Edging (L-L-W-W)	Notes
Front Baffle	White Example Board	29"	11 1/2"	2	0 - 0 - 0 - 0	
Inner Front & Rear Baffle	White Example Board	27 1/2"	10"	4	0 - 0 - 0 - 0	
Sides	White Example Board	29"	21 1/4"	4	0 - 0 - 0 - 0	
Top & Bottom panel	White Example Board	21 1/4"	10"	4	0 - 0 - 0 - 0	
Shelf Brace	White Example Board	19 3/4"	10"	4	0 - 0 - 0 - 0	
Top Vertical Brace	White Example Board	10"	10"	2	0 - 0 - 0 - 0	
Bottom Vertical Brace	White Example Board	7"	10"	2	0 - 0 - 0 - 0	
Top Cabinet Inner Front & Rear Baffle	White Example Board	12"	10"	4	0 - 0 - 0 - 0	
Top Cabinet Sides	White Example Board	13 1/2"	14 1/2"	4	0 - 0 - 0 - 0	
Top Cabinet Top & Bottom	White Example Board	14 1/2"	10"	4	0 - 0 - 0 - 0	
Top Cabinet PVC Support	White Example Board	7 3/8"	10"	4	0 - 0 - 0 - 0	

Input Item List

Client Name :	Job Reference :
Phone Number :	Quote Number :
Fax Number :	Quantity : 2
Address :	Date Required : 8/25/2017

Input Panel

Code	Material	Length	Width	Qty	Edging (L-L-W-W)	Notes
Top Cabinet Outer Front Baffle	Grain Example Board	14"	12"	2	0 - 0 - 0 - 0	This is oversize. Trim for exact fit with Router
Top Cabinet Shelf Brace	Grain Example Board	13"	10"	2	0 - 0 - 0 - 0	Cut a 4" x 4" notch out of one rear corner for wiring access

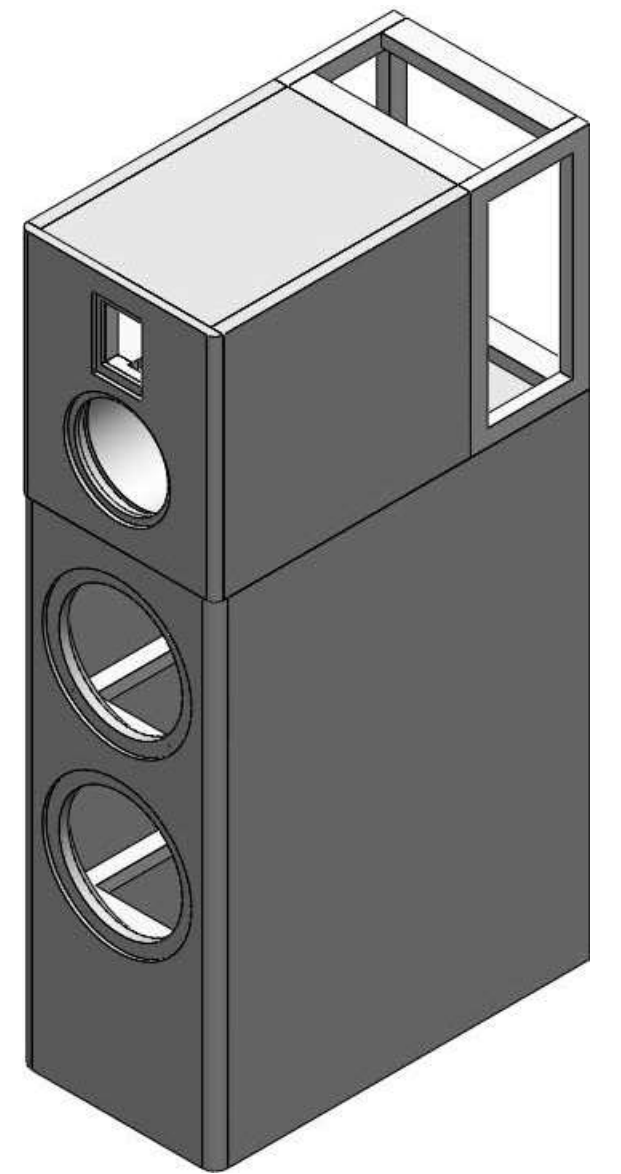
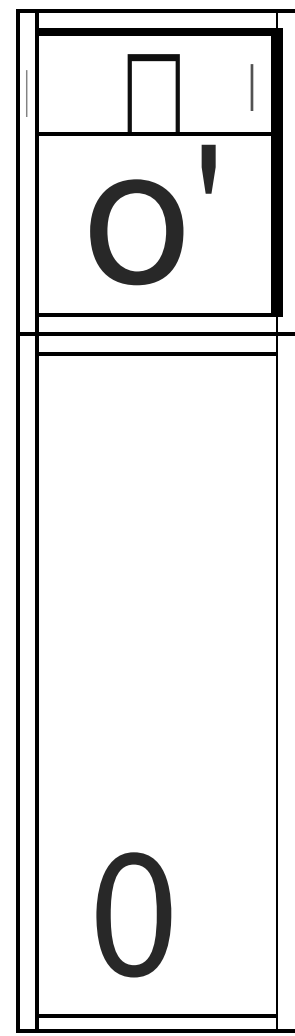
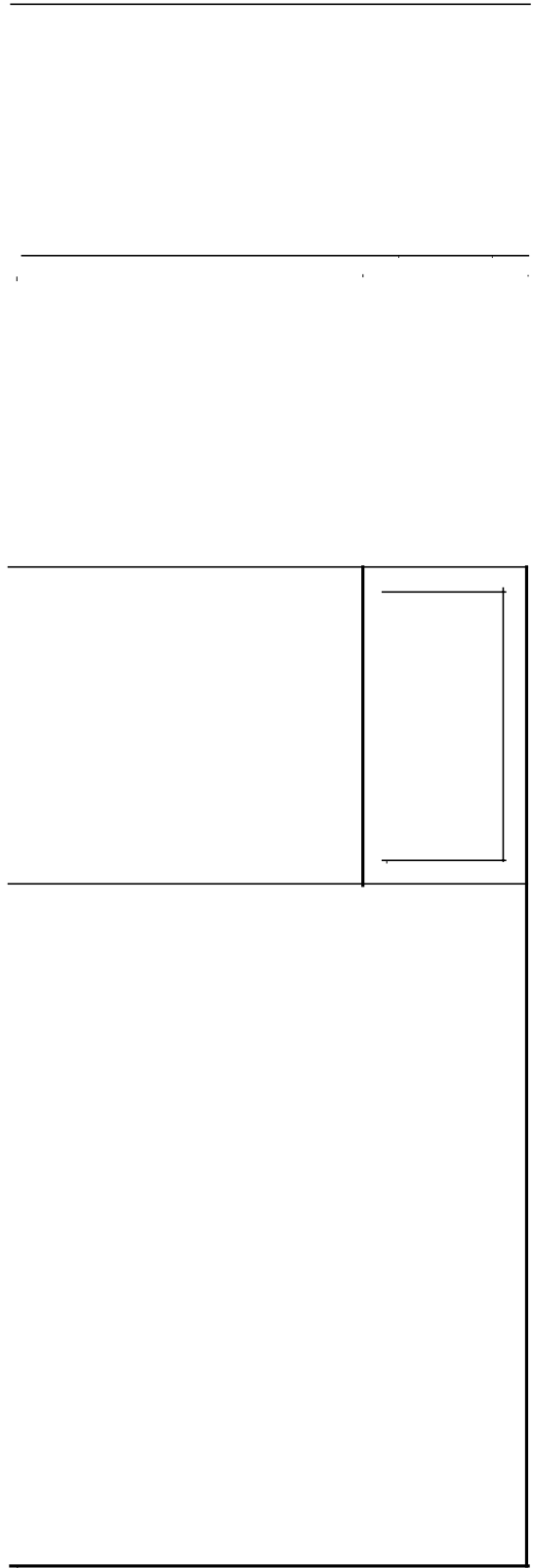
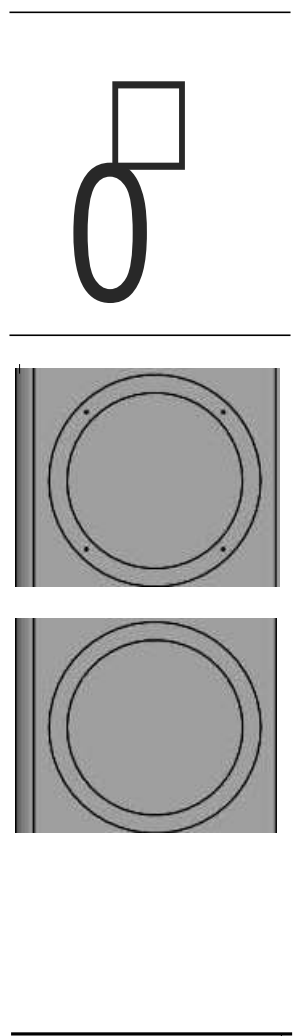
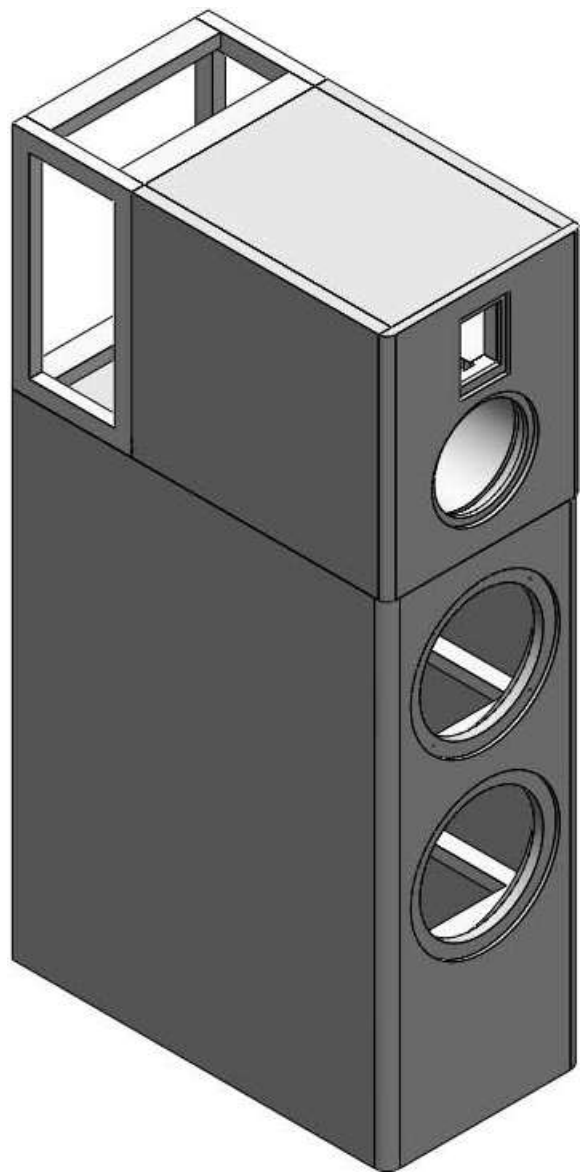

BASS MODULE

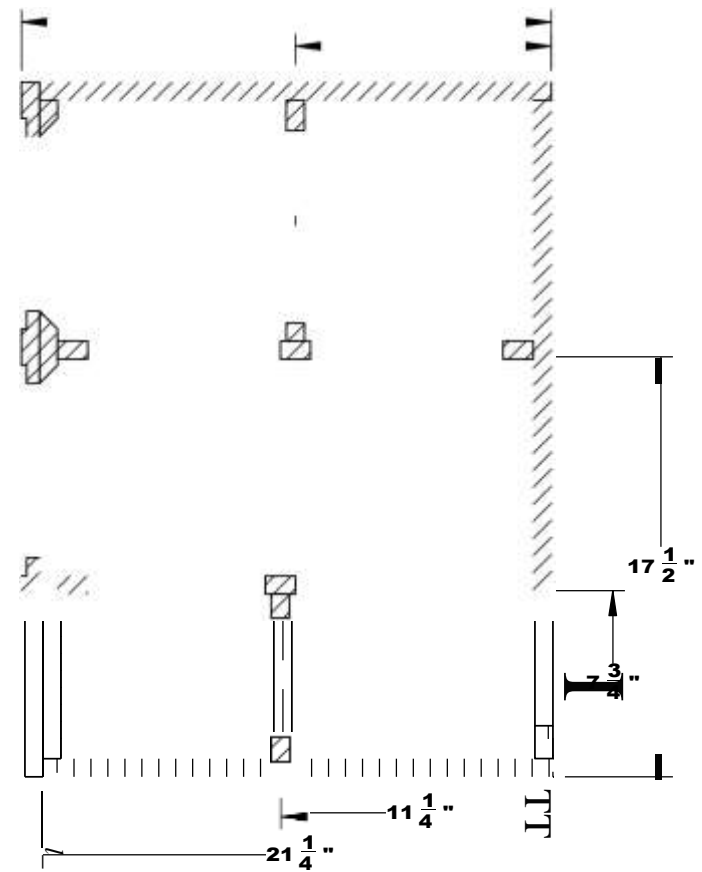
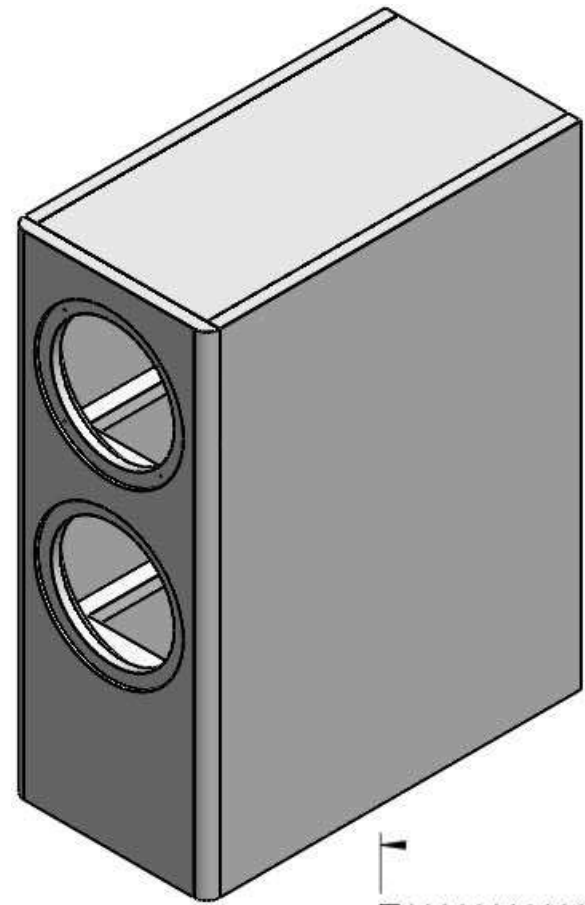

SECTION A-A
SCALE 1 : 4

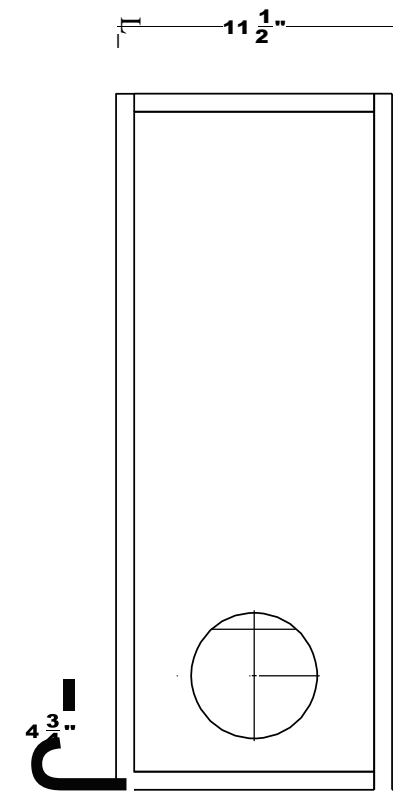
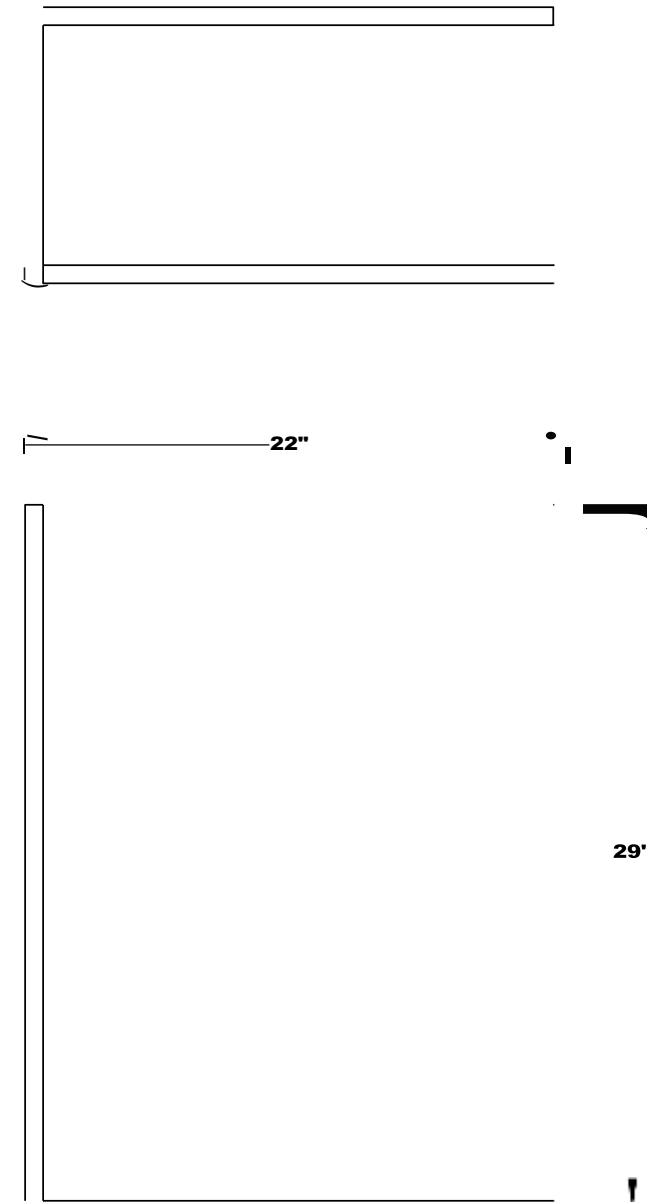
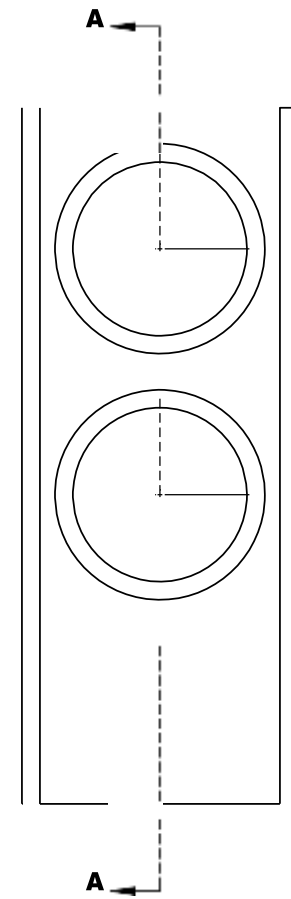

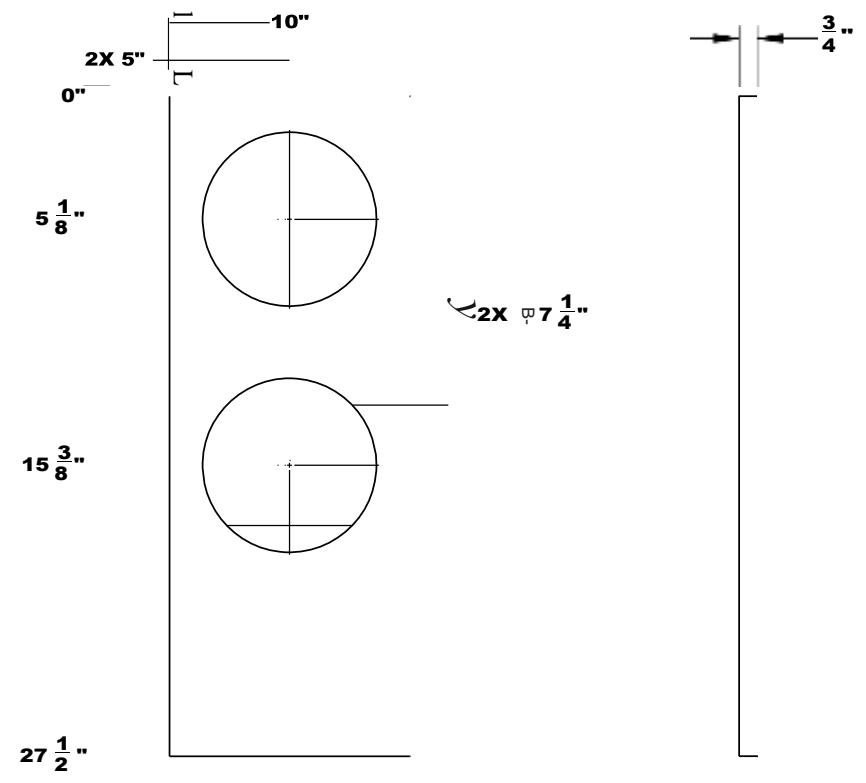
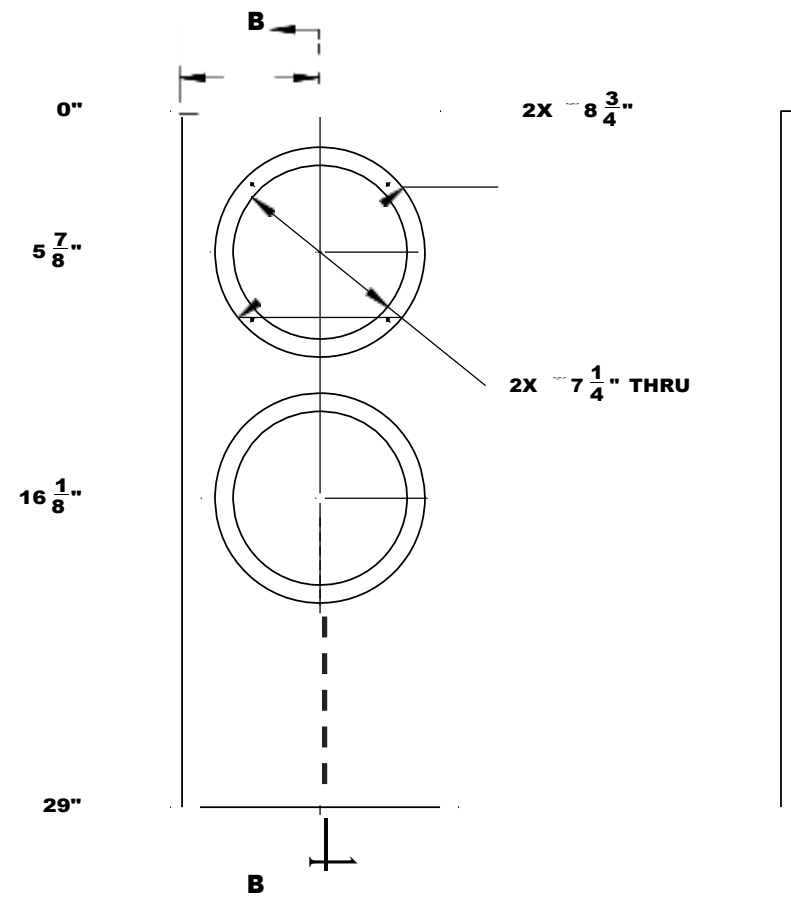
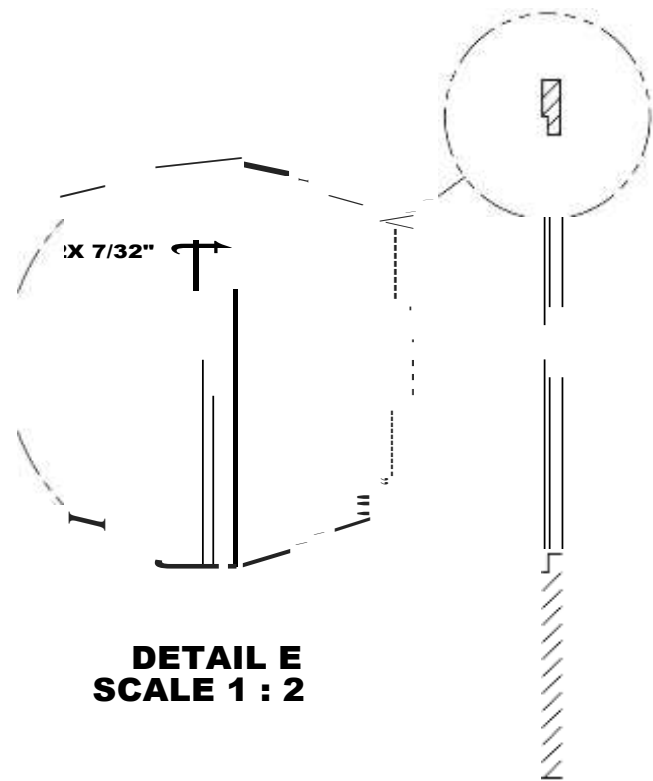
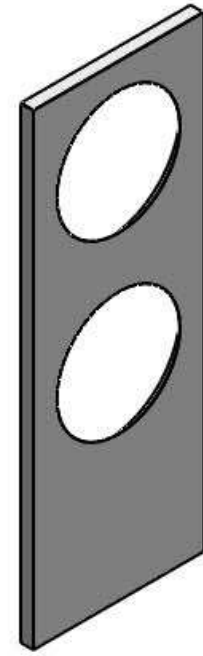
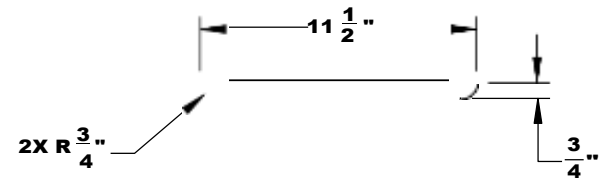
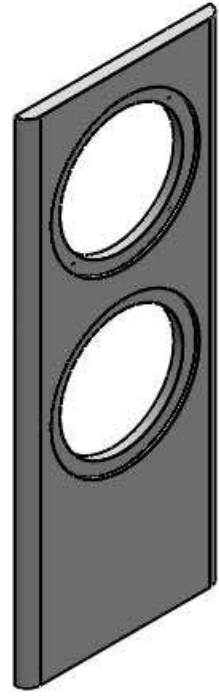

**DETAIL E
SCALE 1 : 2**

SECTION B-B

**OUTER FRONT BAFFLE
SCALE: 1/4**

**INNER FRONT BAFFLE
SCALE: 1/4**

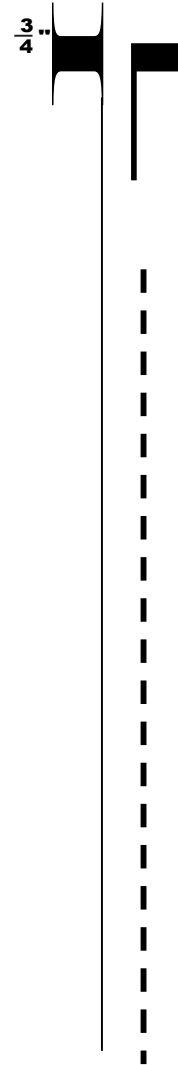
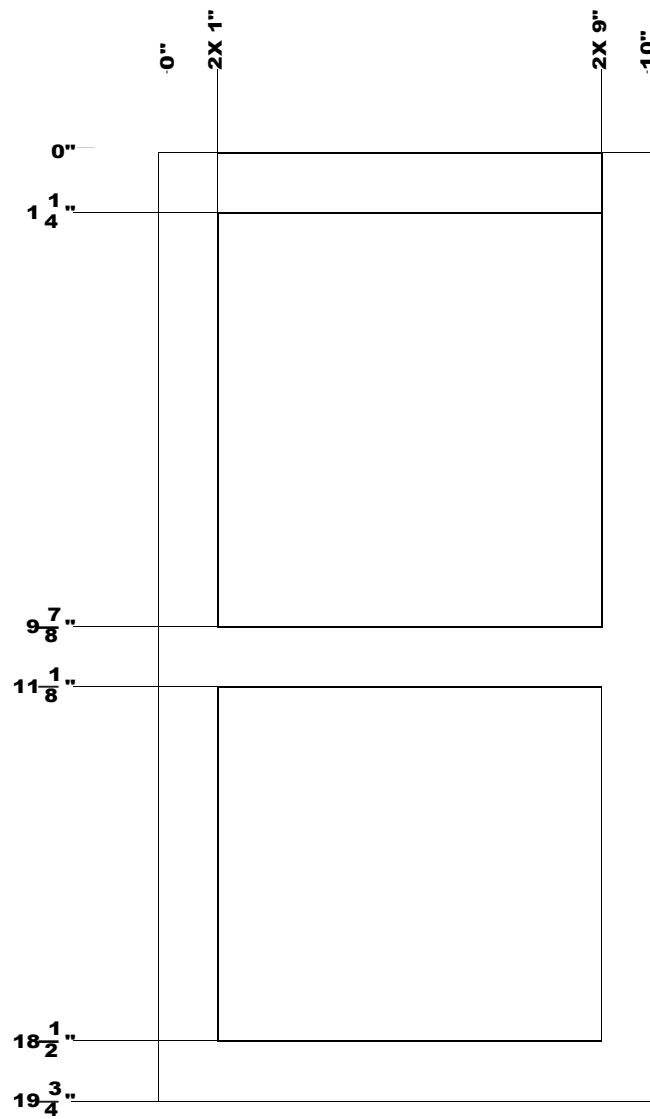
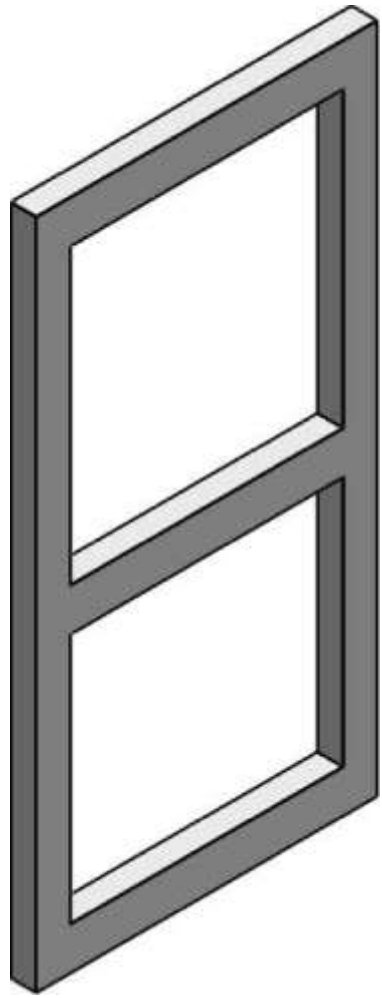

LOWER SHELF
SCALE: 1/2

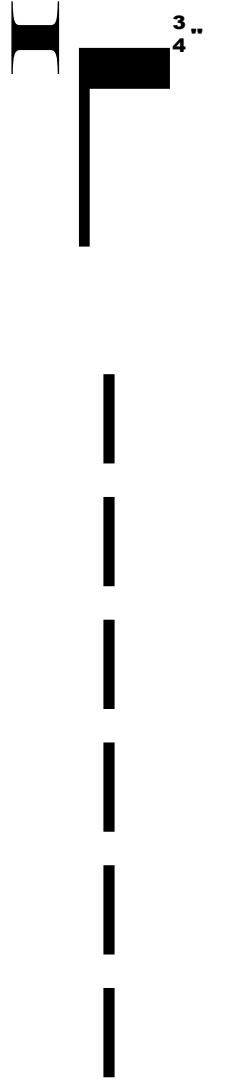
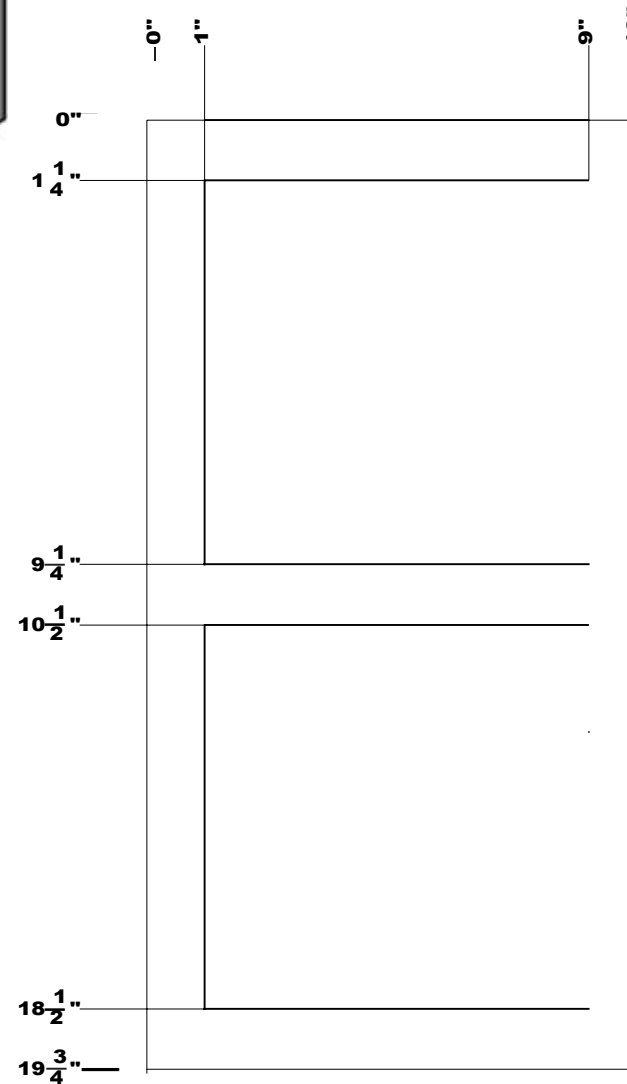
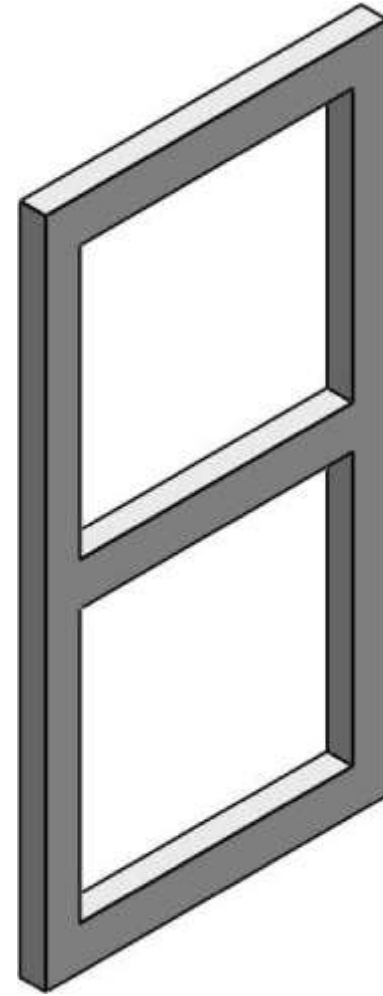

UPPER SHELF
SCALE: 1/2

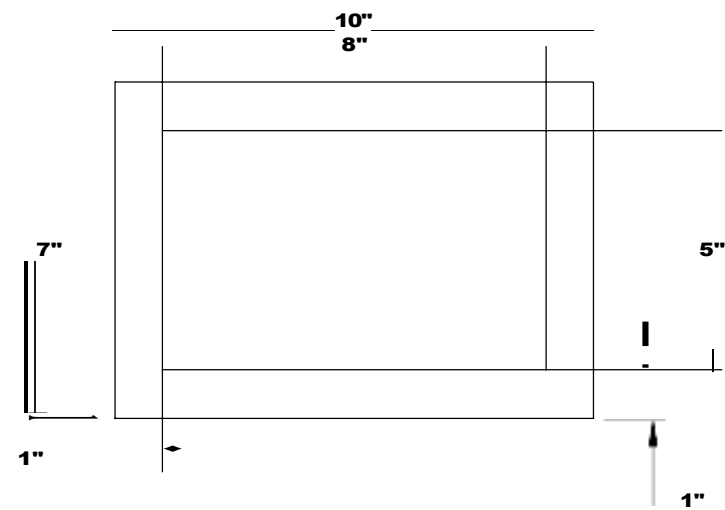
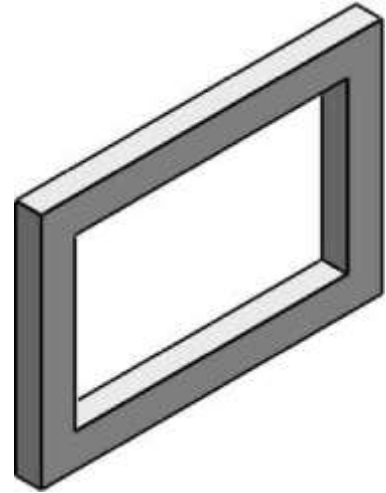

LOWER SHELF BRACE
SCALE: 1/2

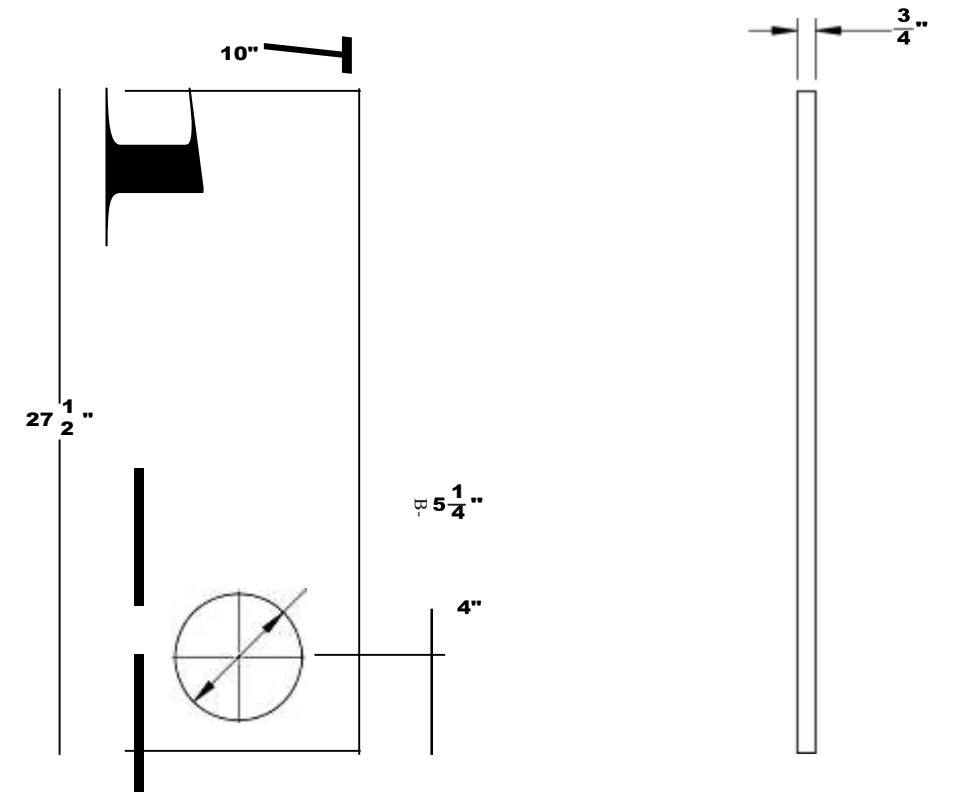
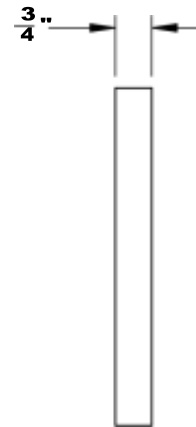

PANEL REAR
SCALE: 1/4

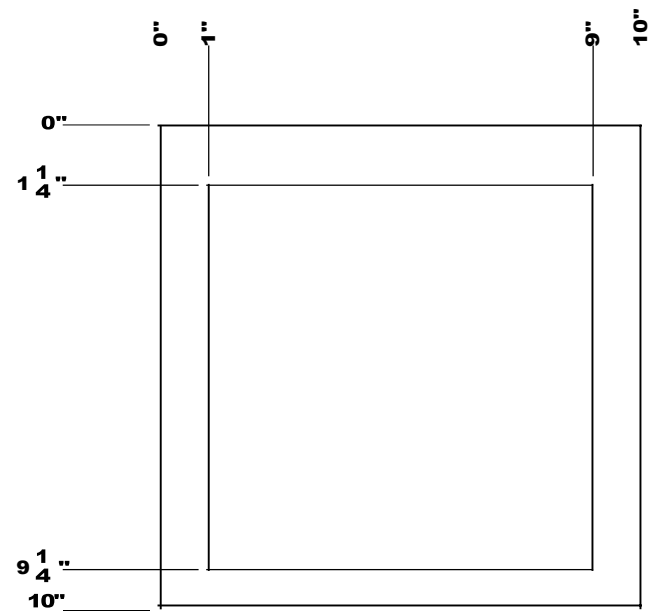
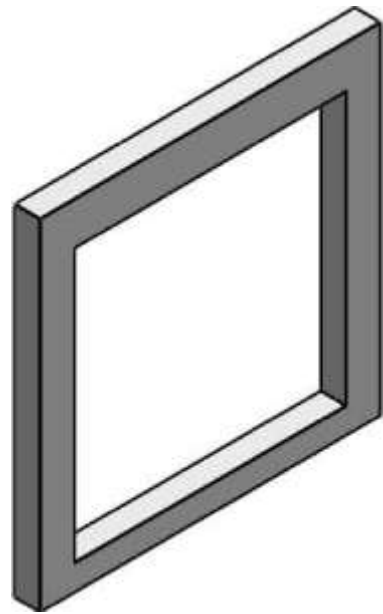

UPPER SHELF BRACE
SCALE: 1/2

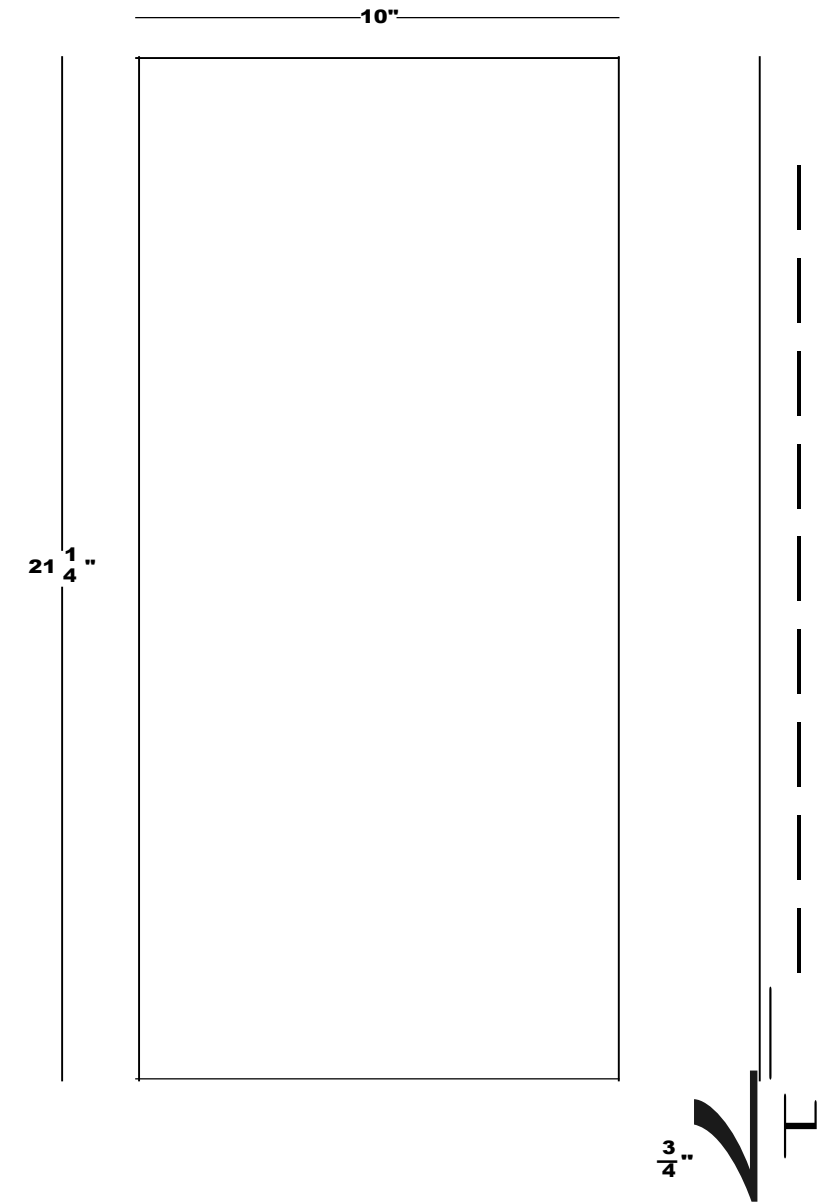
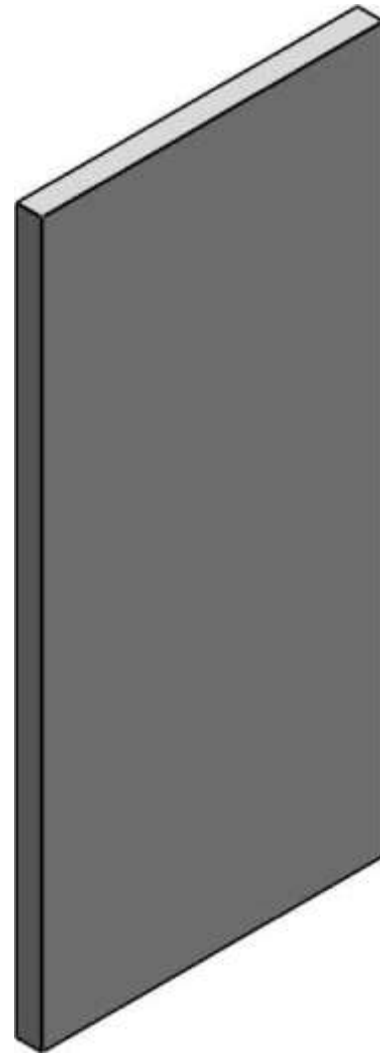
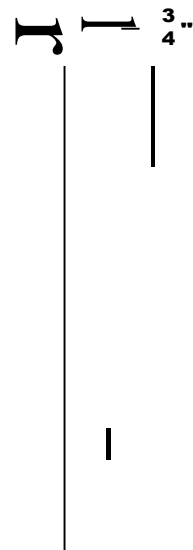

TOP/BOTTOM PANEL
SCALE: 1/2

BASS MODULE_EXPLODED VIEW

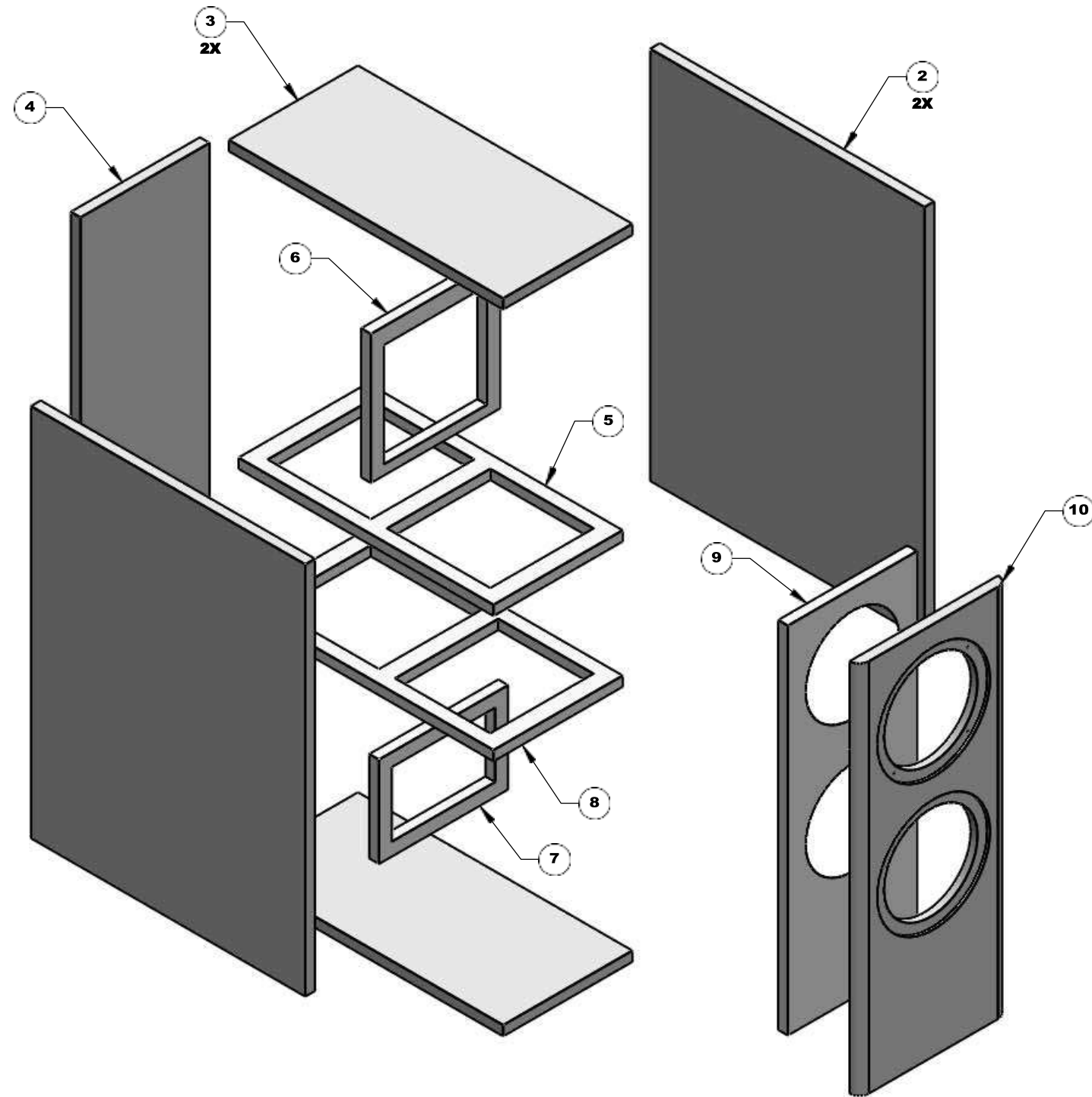

FIND NO.	QTY REQ	PART NAME
1	2	SIDE
2	2	TOP_BOTTOM
3	1	BAFFLE, REAR
4	1	SHELF, UPPER
5	1	BRACE, UPPER
6	1	BRACE, LOWER
7	1	BRACE, LOWER SHELF
8	1	FRONT BAFFLE
	1	BAFFLE, OUTER FRONT
	1	BAFFLE, INNER FRONT

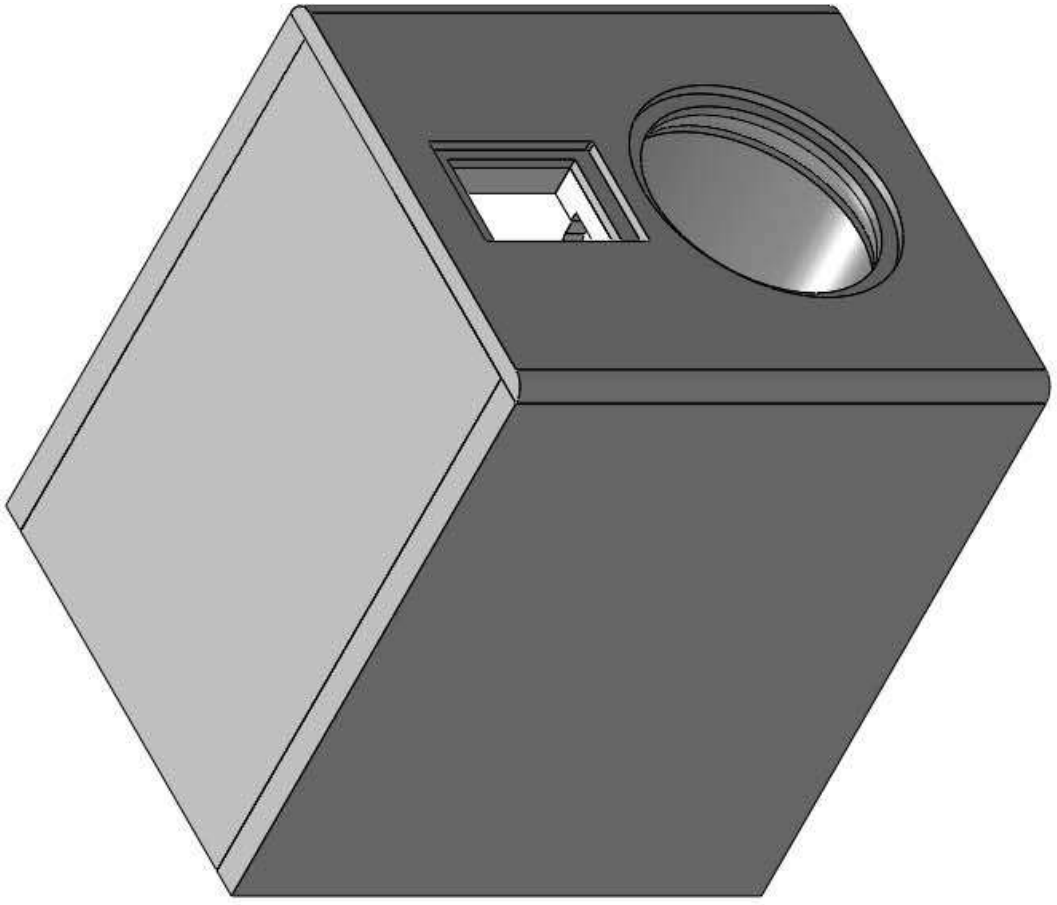

MID-RANGE MODULE

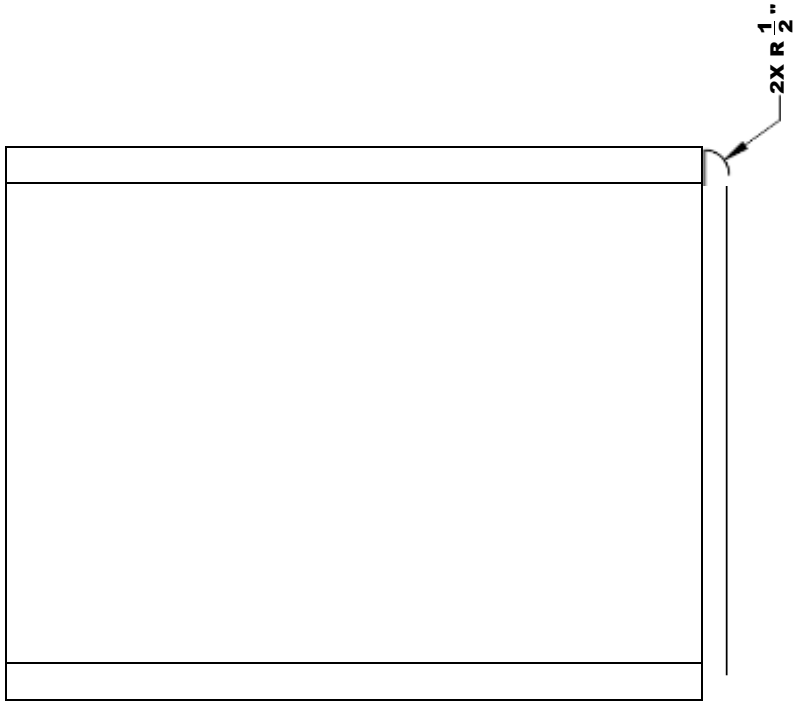

11 1/2"

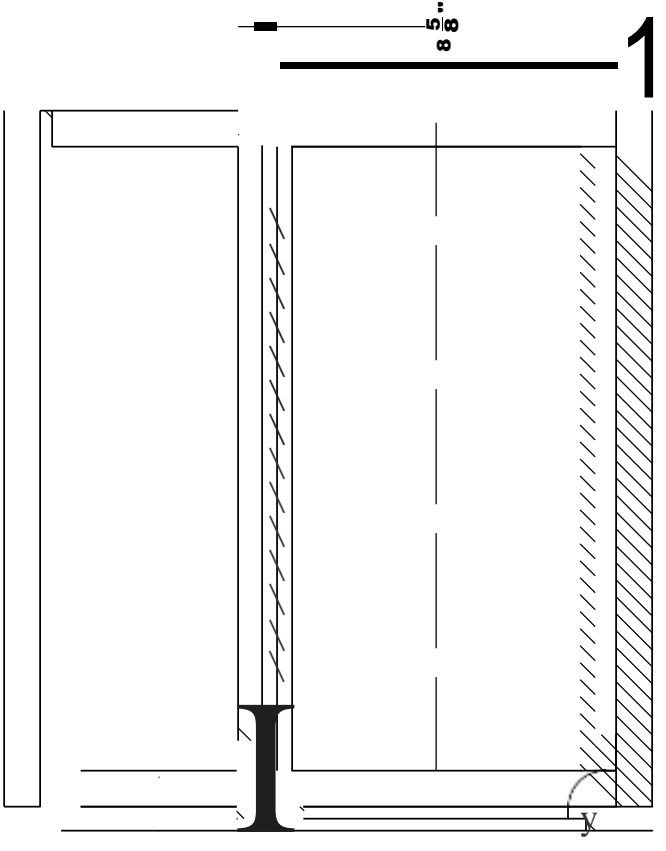
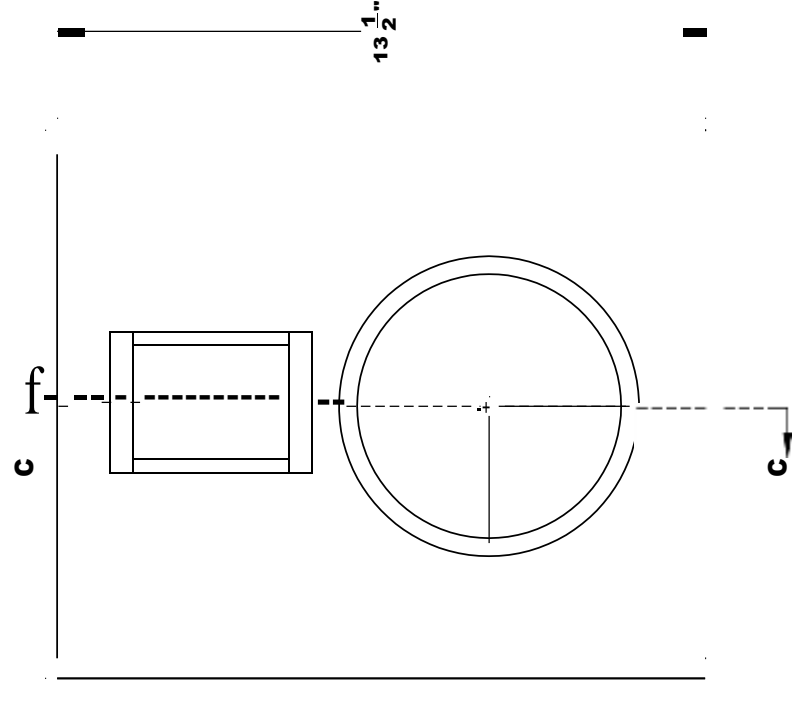
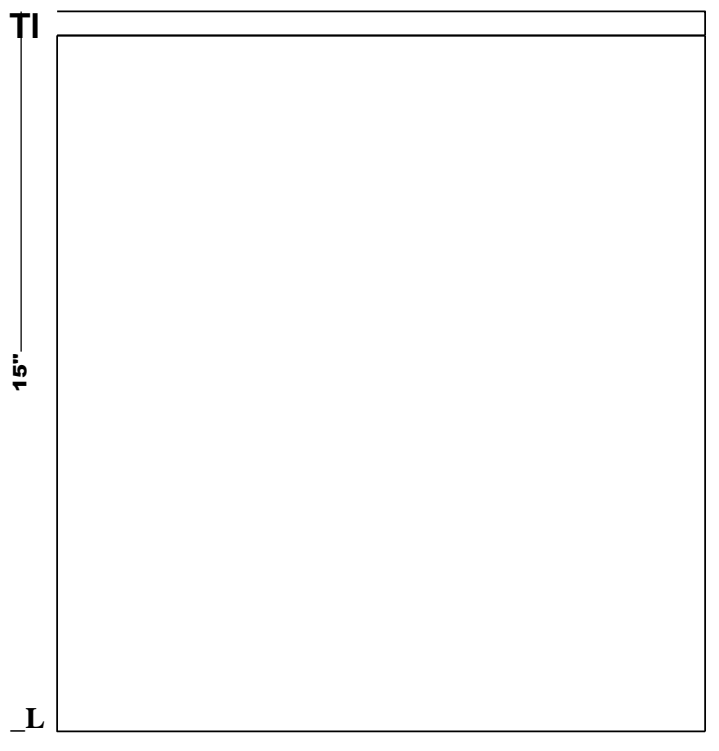

**SECTION C-C
SCALE 1 : 2**

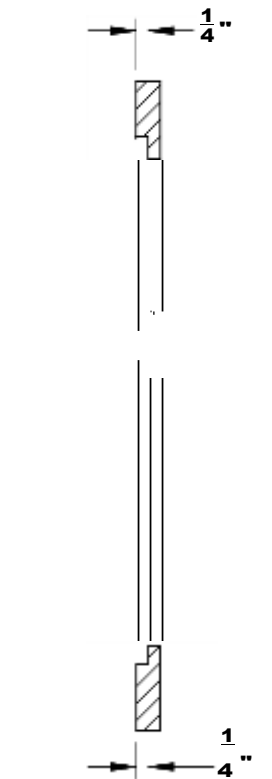
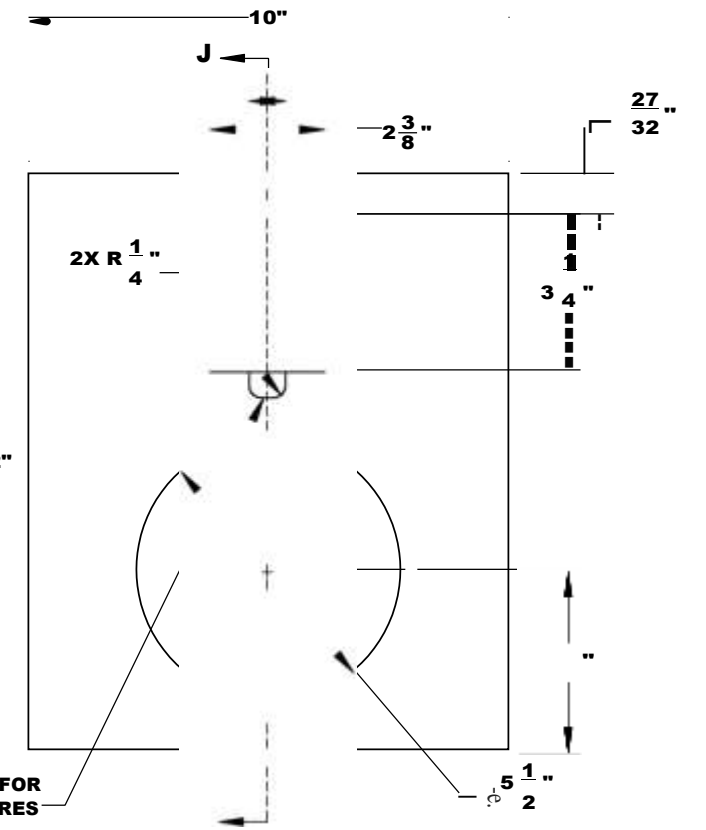
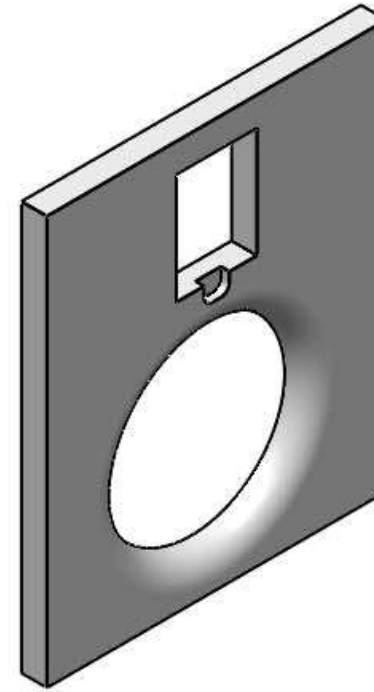
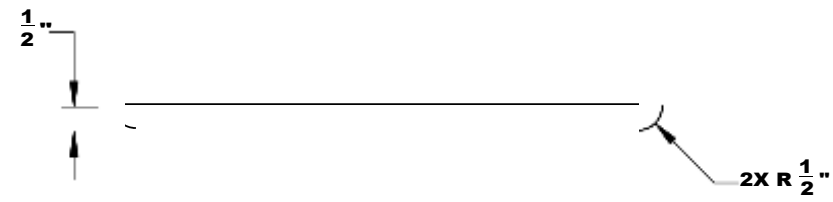
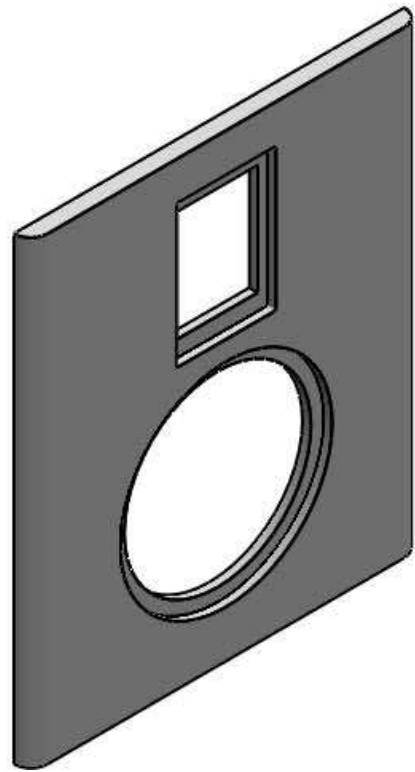

SECTION H-H

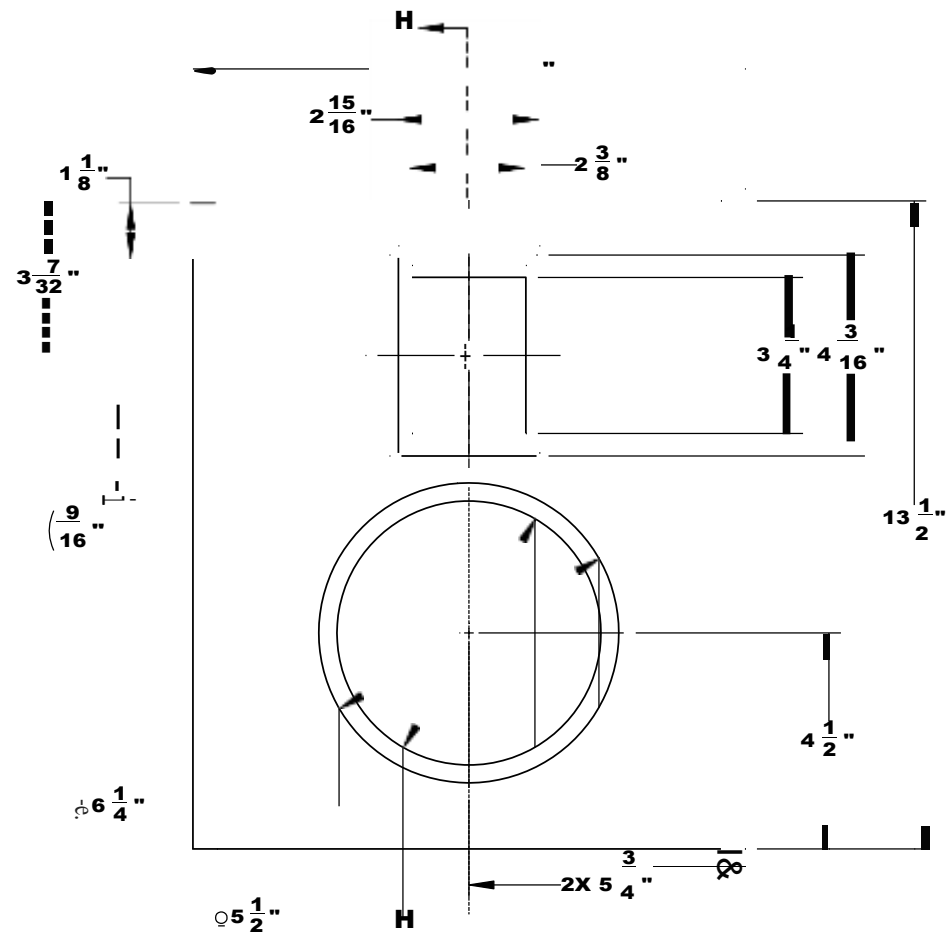

**OUTER FRONT BAFFLE
SCALE: 1/2**

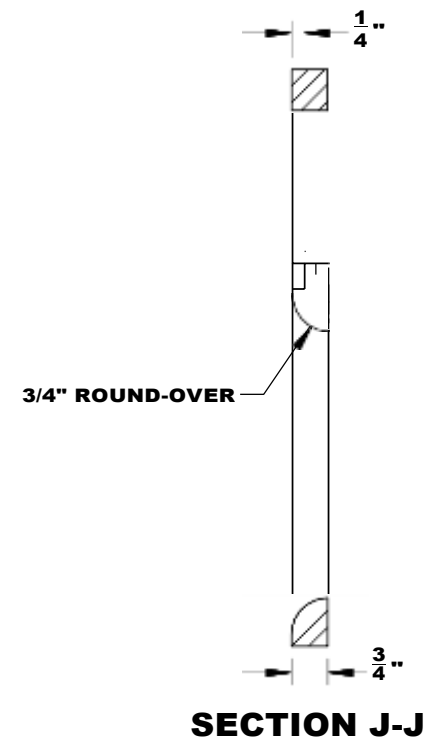

SECTION J-J

**INNER FRONT BAFFLE
SCALE: 1/2**

RELIEF FOR RIBBON WIRES

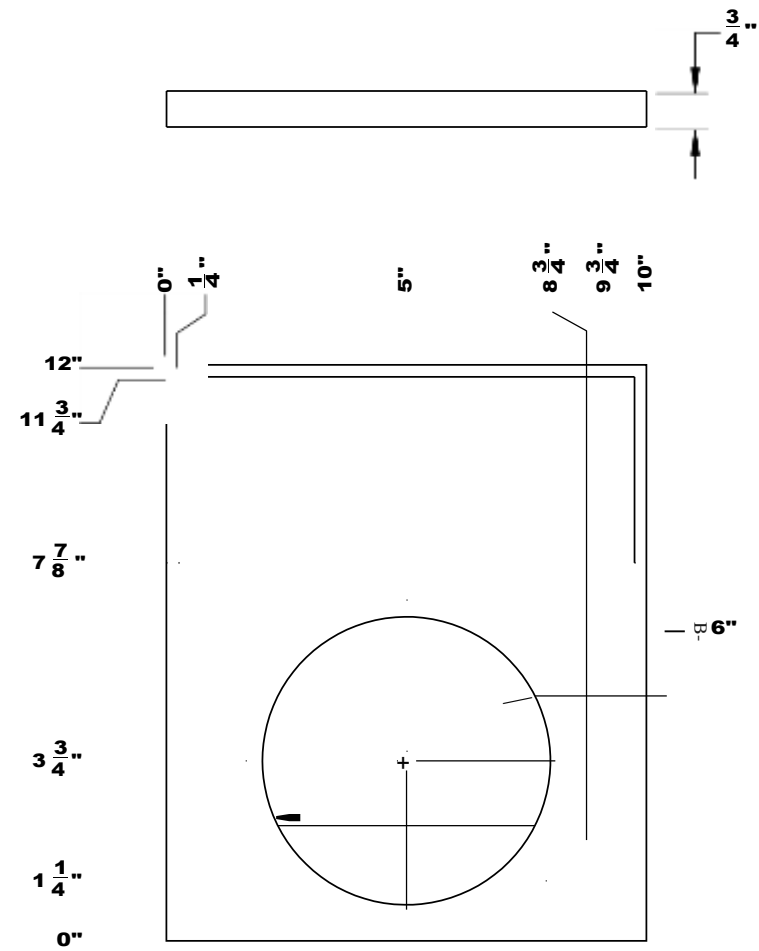
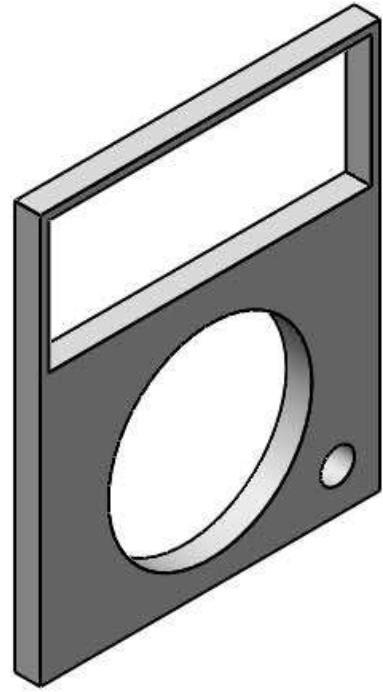

REAR PANEL
SCALE: 1/2

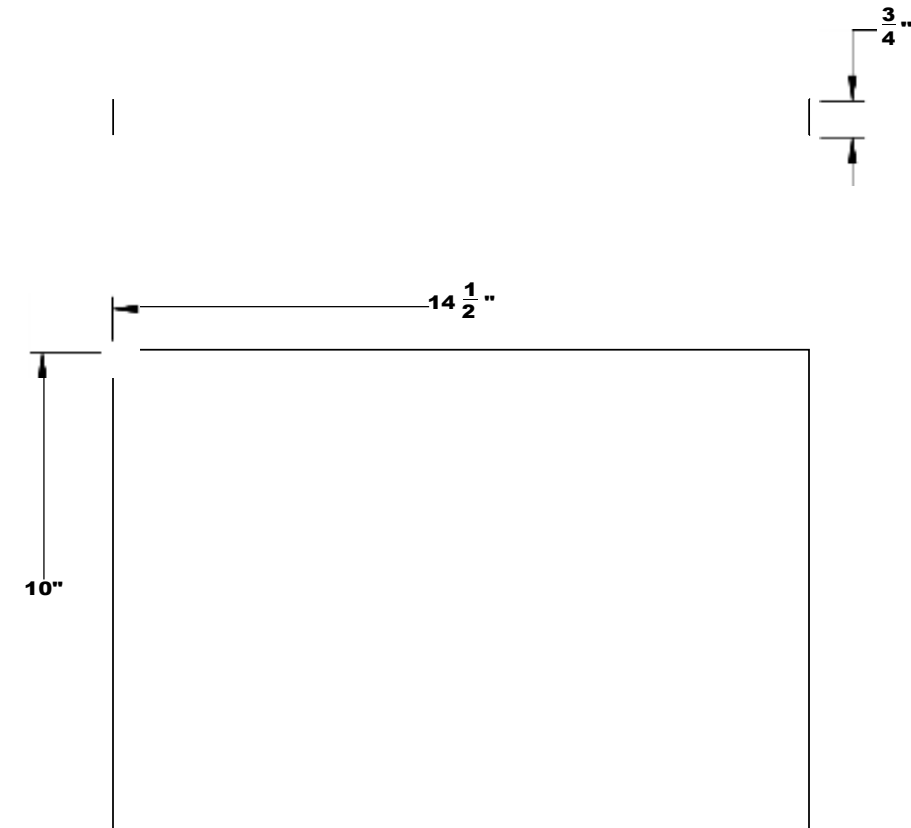
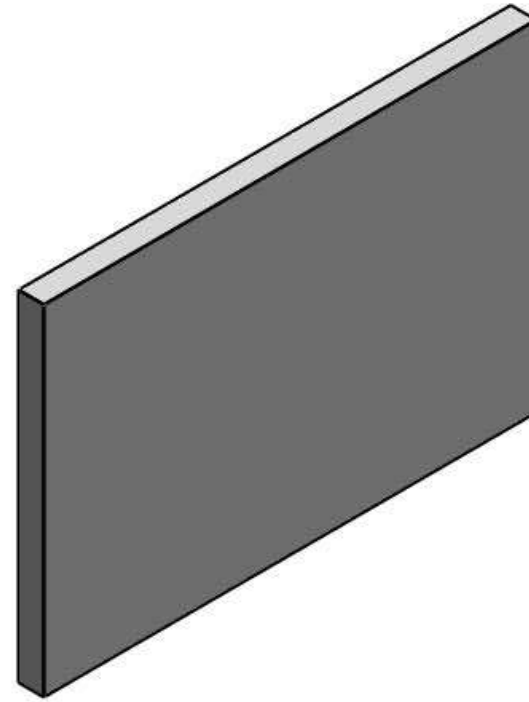

TOP PANEL
SCALE: 1/2

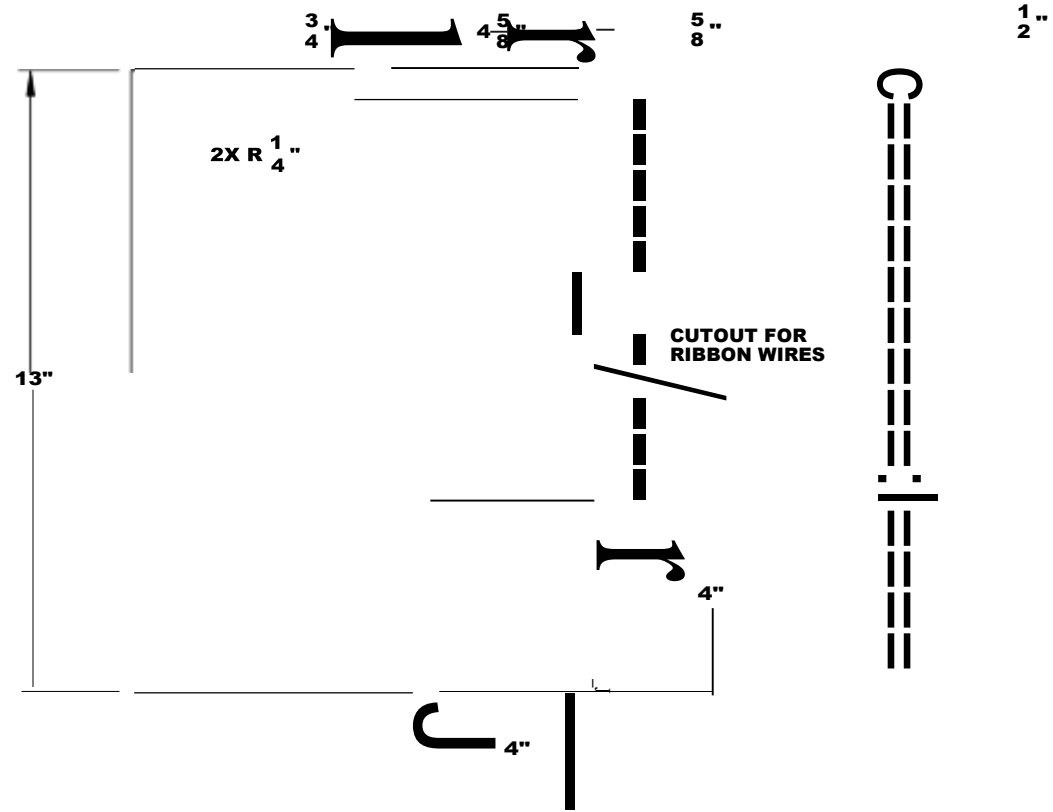
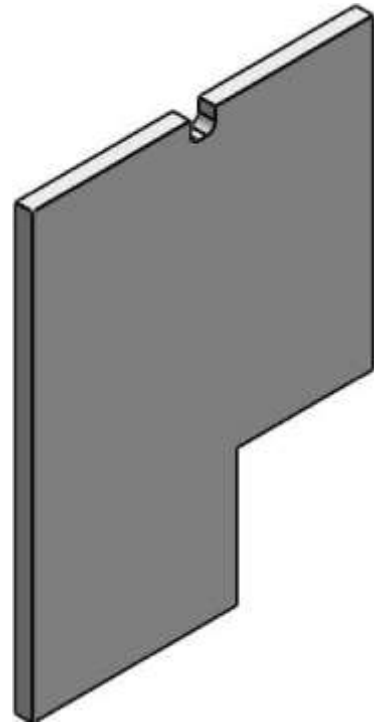

MIDDLE SHELF
SCALE: 1/2

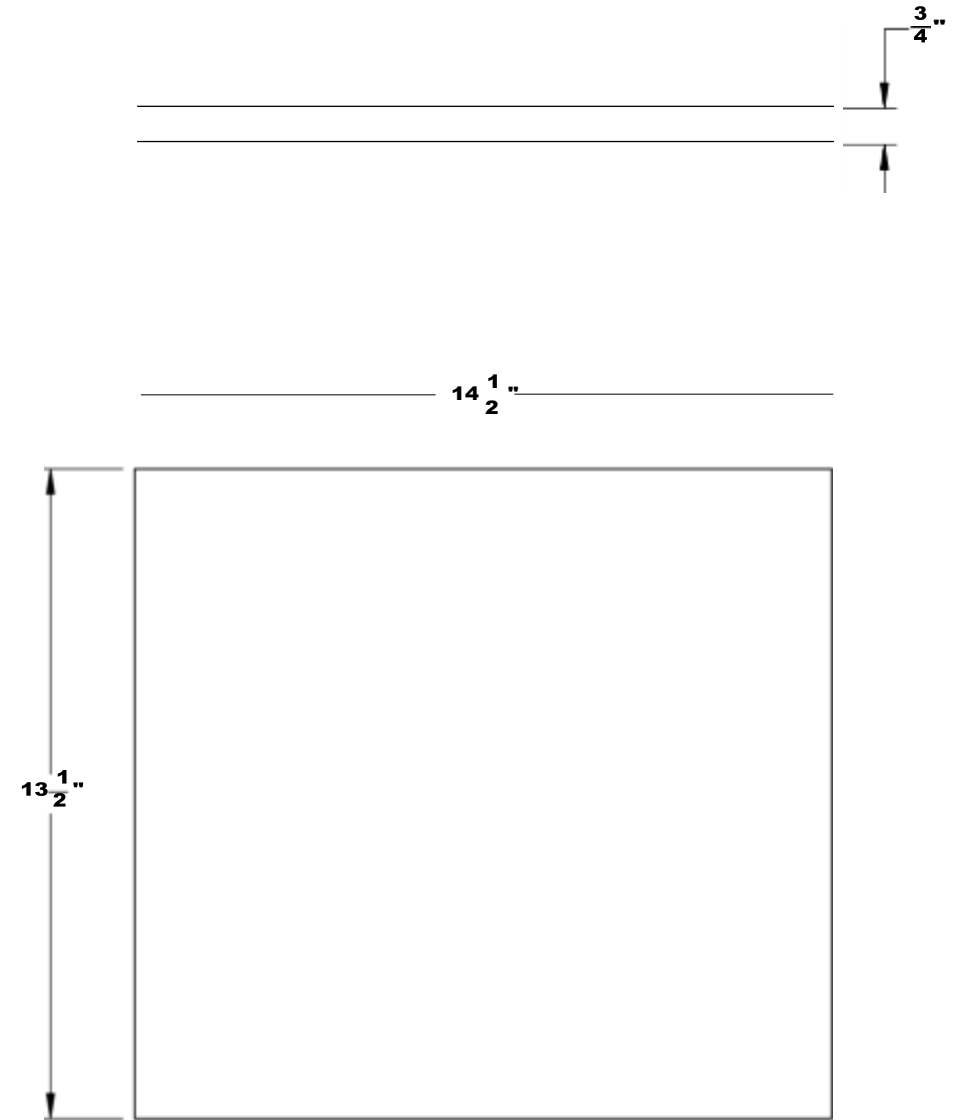

SIDE PANEL
SCALE: 1/2

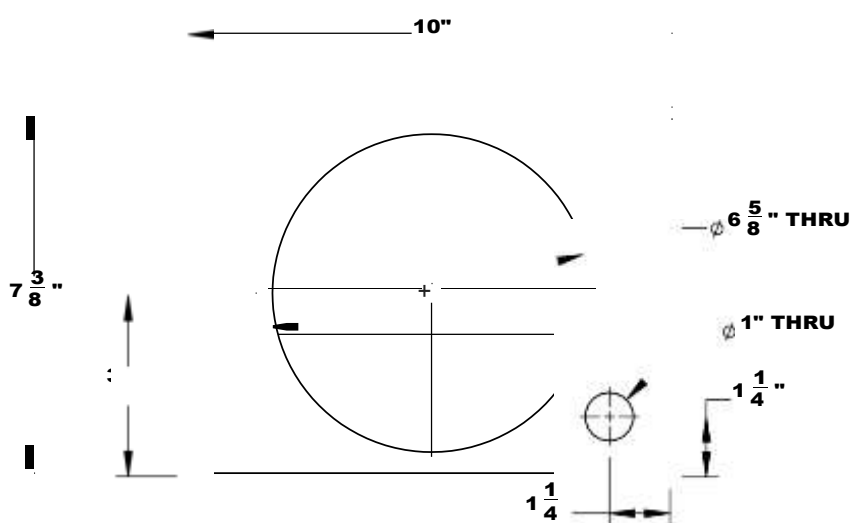
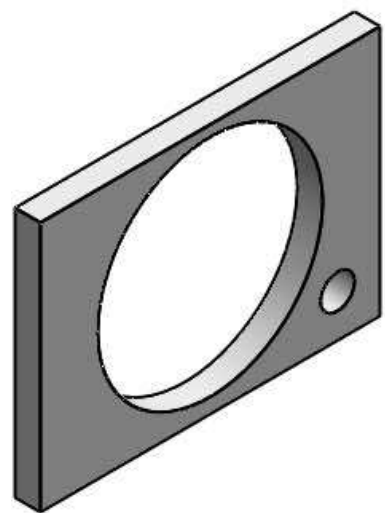

REAR MID-TUNNEL SUPPORT
SCALE: 1/2

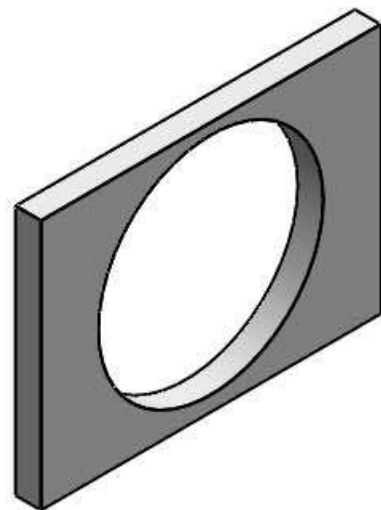

3/4"

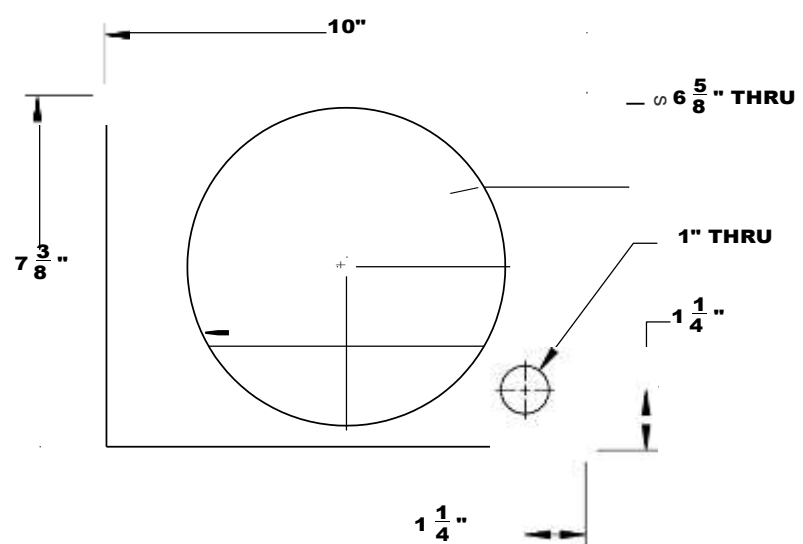

FRONT MID TUNNEL SUPPORT
SCALE: 1/2

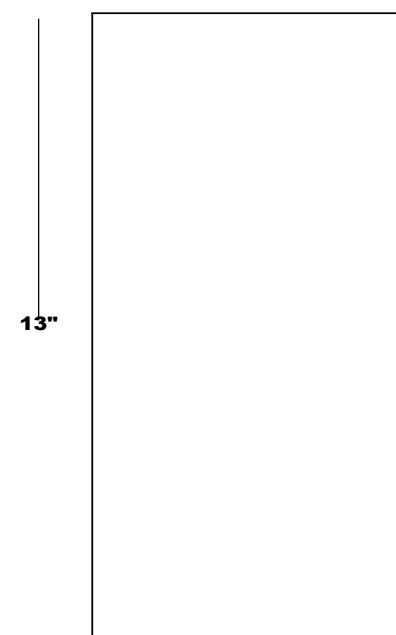
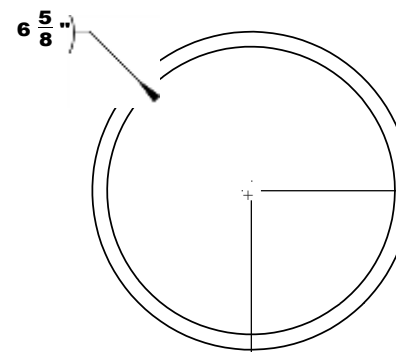
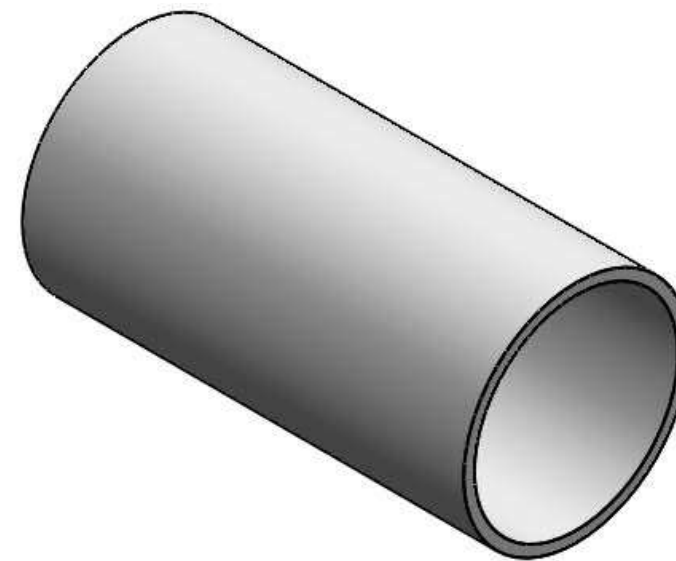

MID- WOOFER TUNNEL
SCALE: 1/2

MID-RANGE MODULE_EXPLODED VIEW

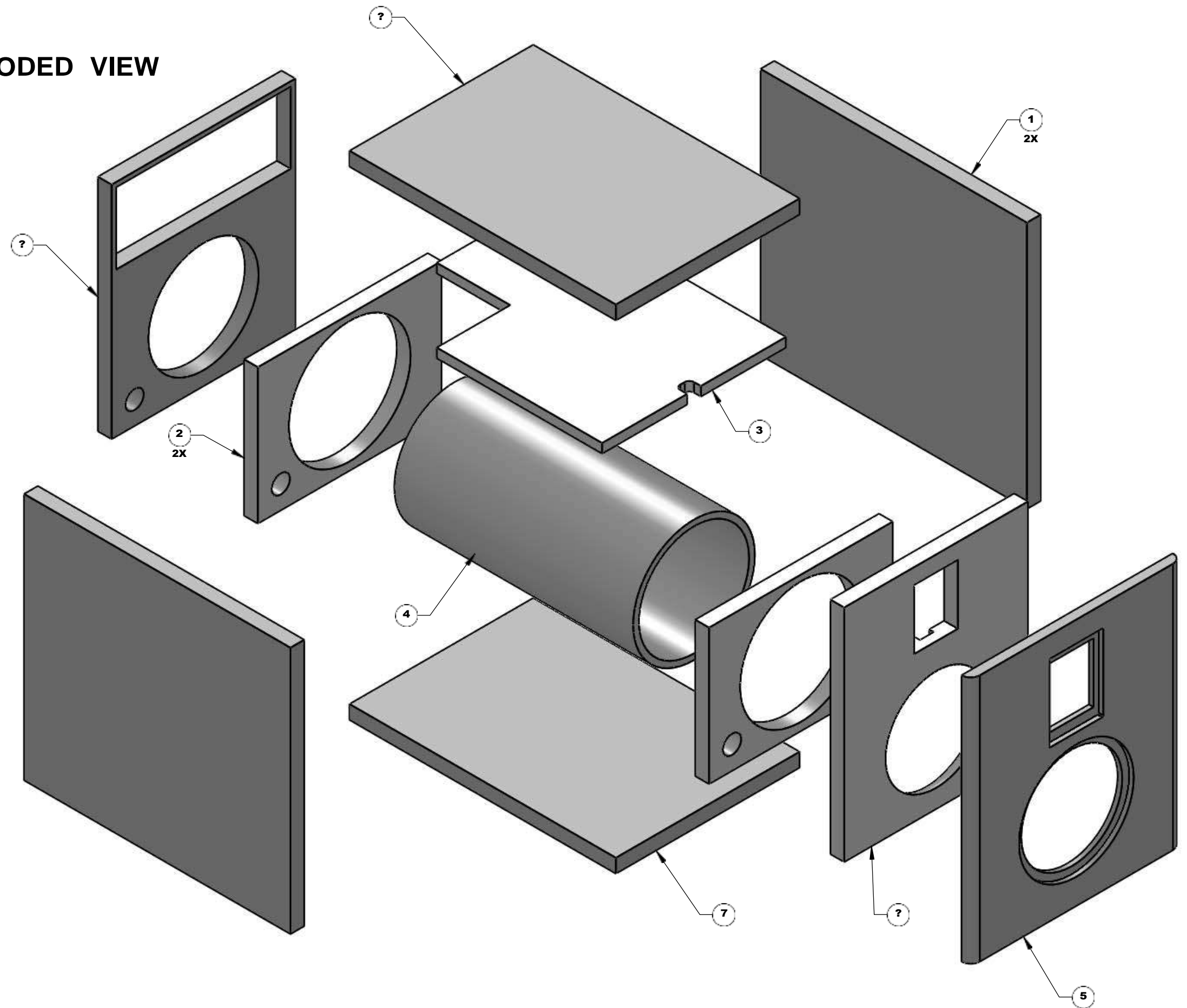

FIND NO.	QTY REQ	PART NO.
1	2	SIDE PANEL, TOP MODULE
2	2	SUPPORT, PVC
3	1	STIFFENER, TOP MODULE
4	1	TUNNEL, PVC
5	1	FRONT BAFFLE, TOP
6	1	INNER BAFFLE, TOP MODULE
7	2	TOP PANEL, TOP MODULE
8	1	REAR PANEL, TOP

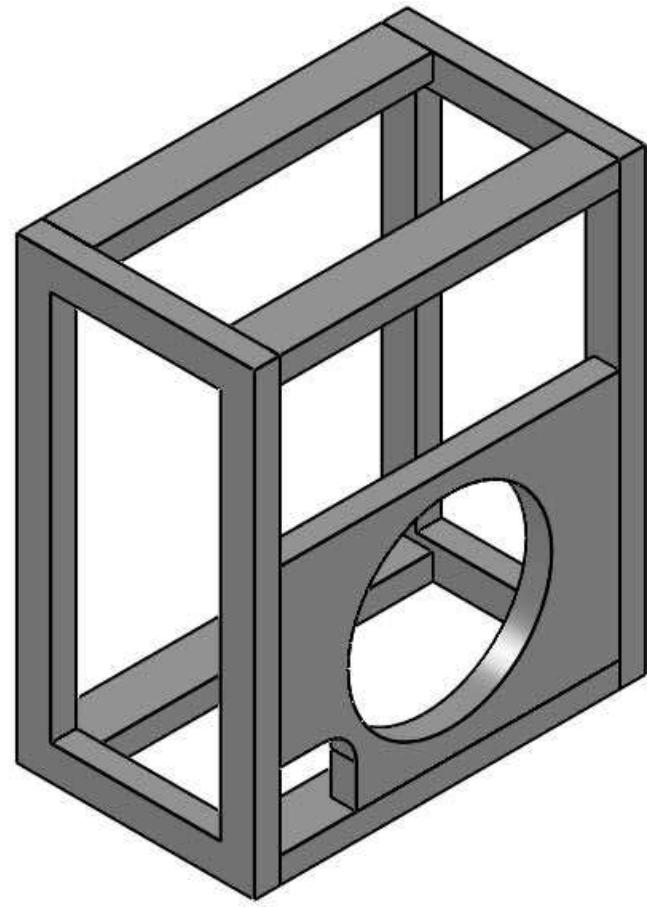

REAR GRILL STRUCTURE

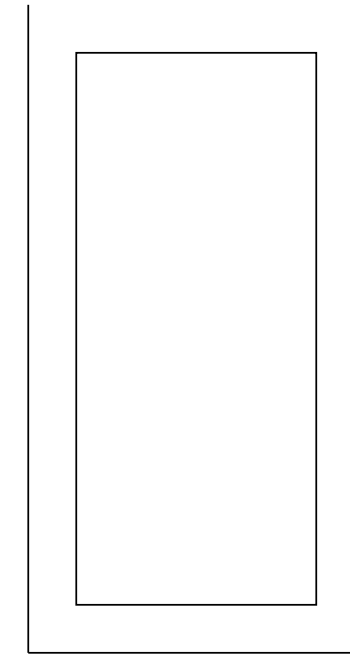
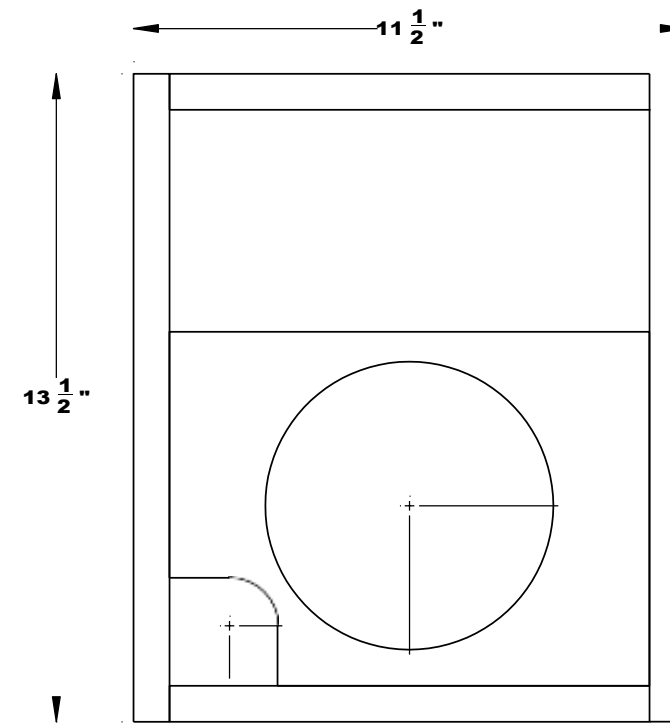
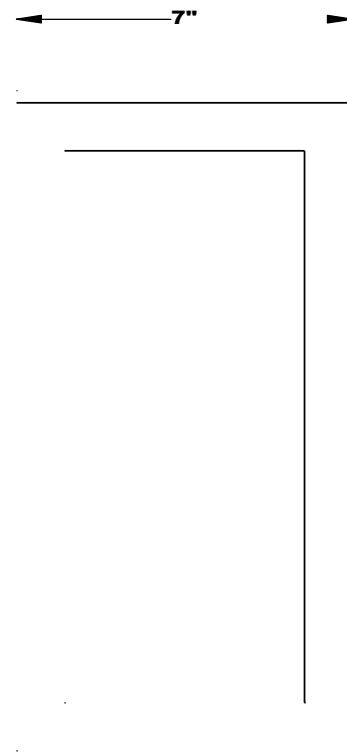

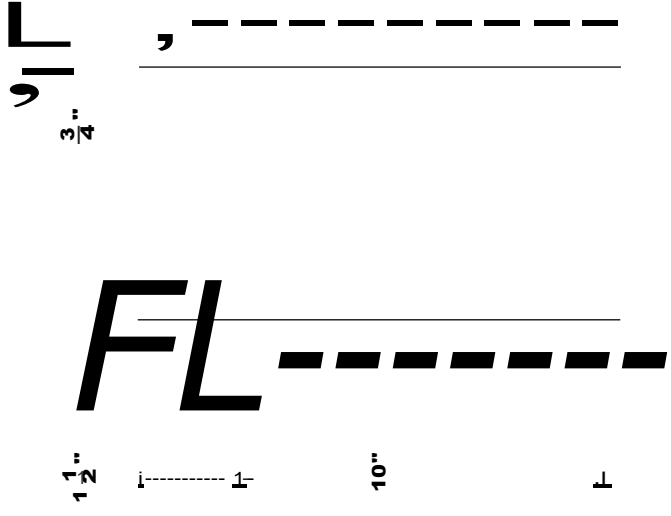

STRETCHER, GRILL STRUCTURE
SCALE: 1/2

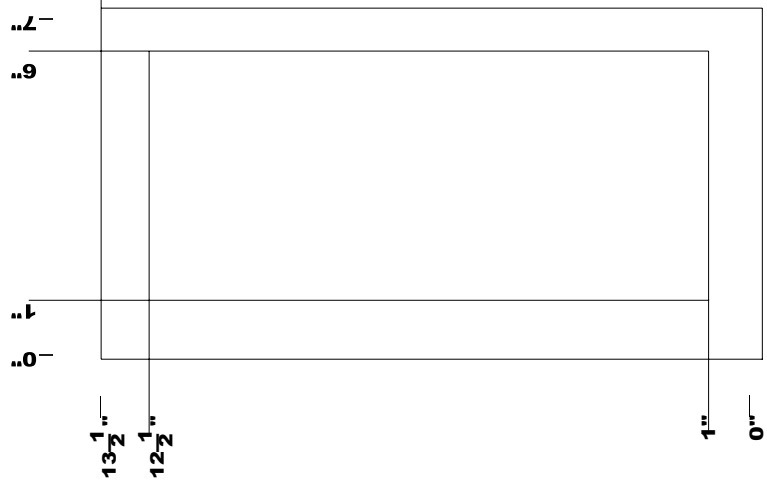

SIDE PANEL, GRILL STRUCTURE
SCALE: 1/2

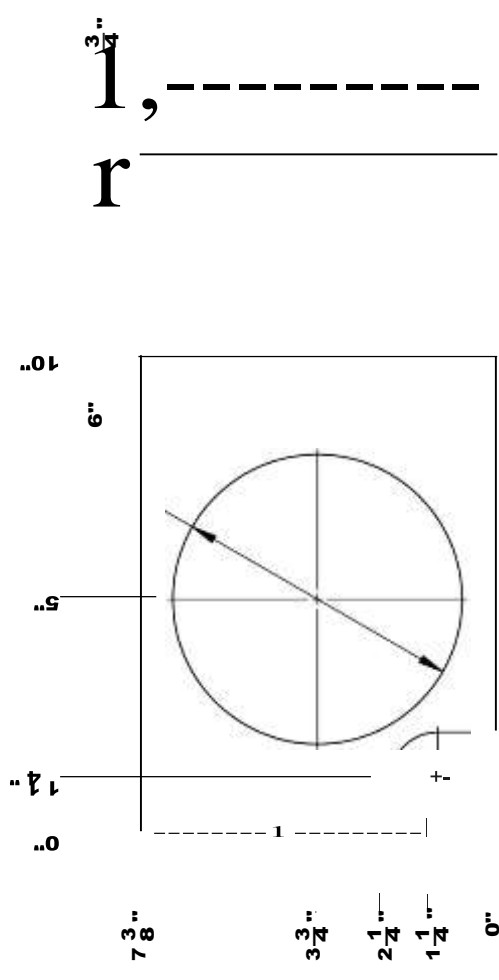

FRONT PANEL, GRILL STRUCTURE
SCALE: 1/2

REAR GRILL STRUCTURE_EXPLODED VIEW

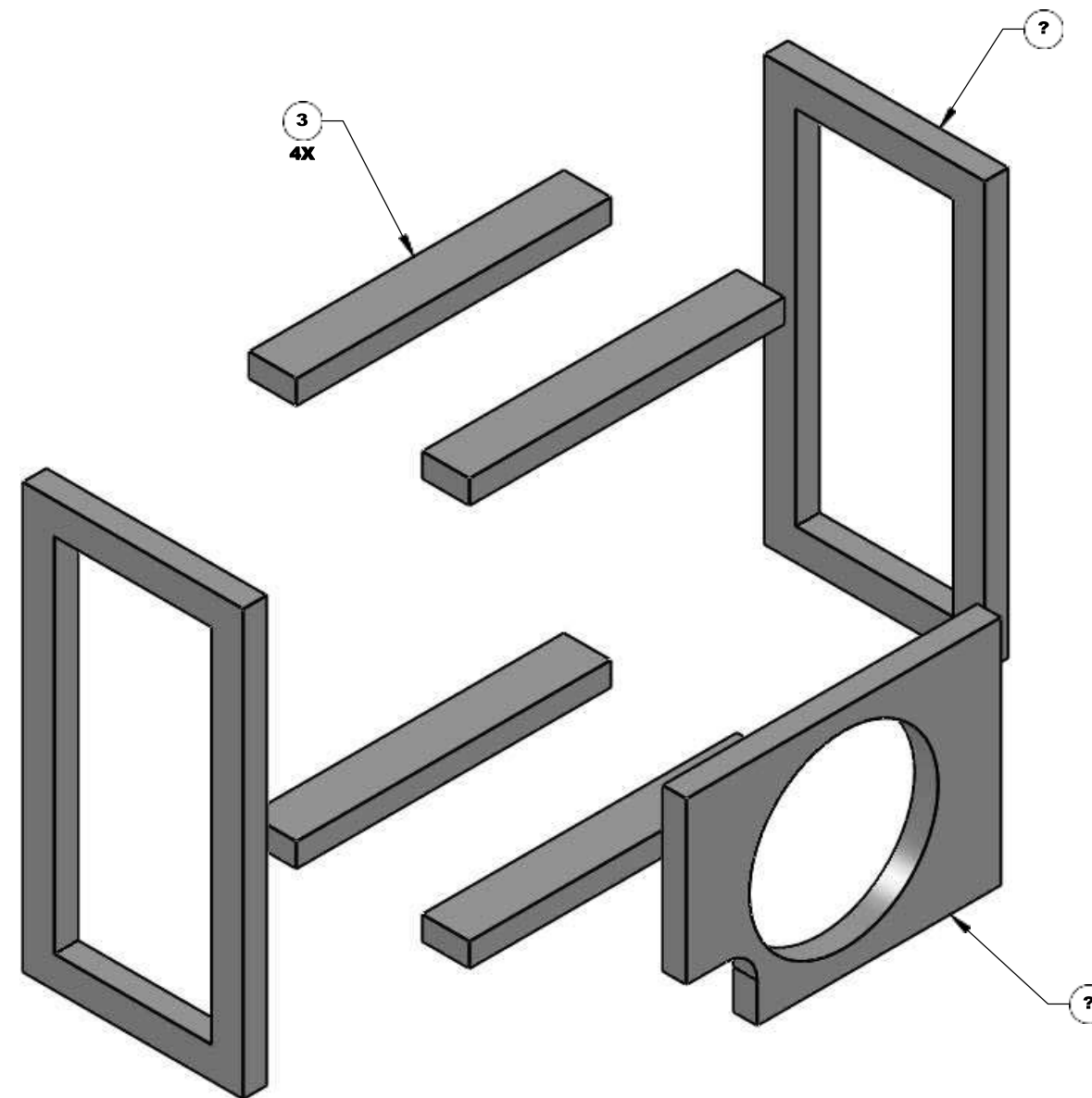

FIND NO.	QTY REQ	PART NO.
1	2	SIDE PANEL, GRILL
2	1	FRONT, GRILL STRUCTURE
3	4	STRETCHER, GRILL STRUCTURE